





Property of
TRIUMF
Instrumentation Pool

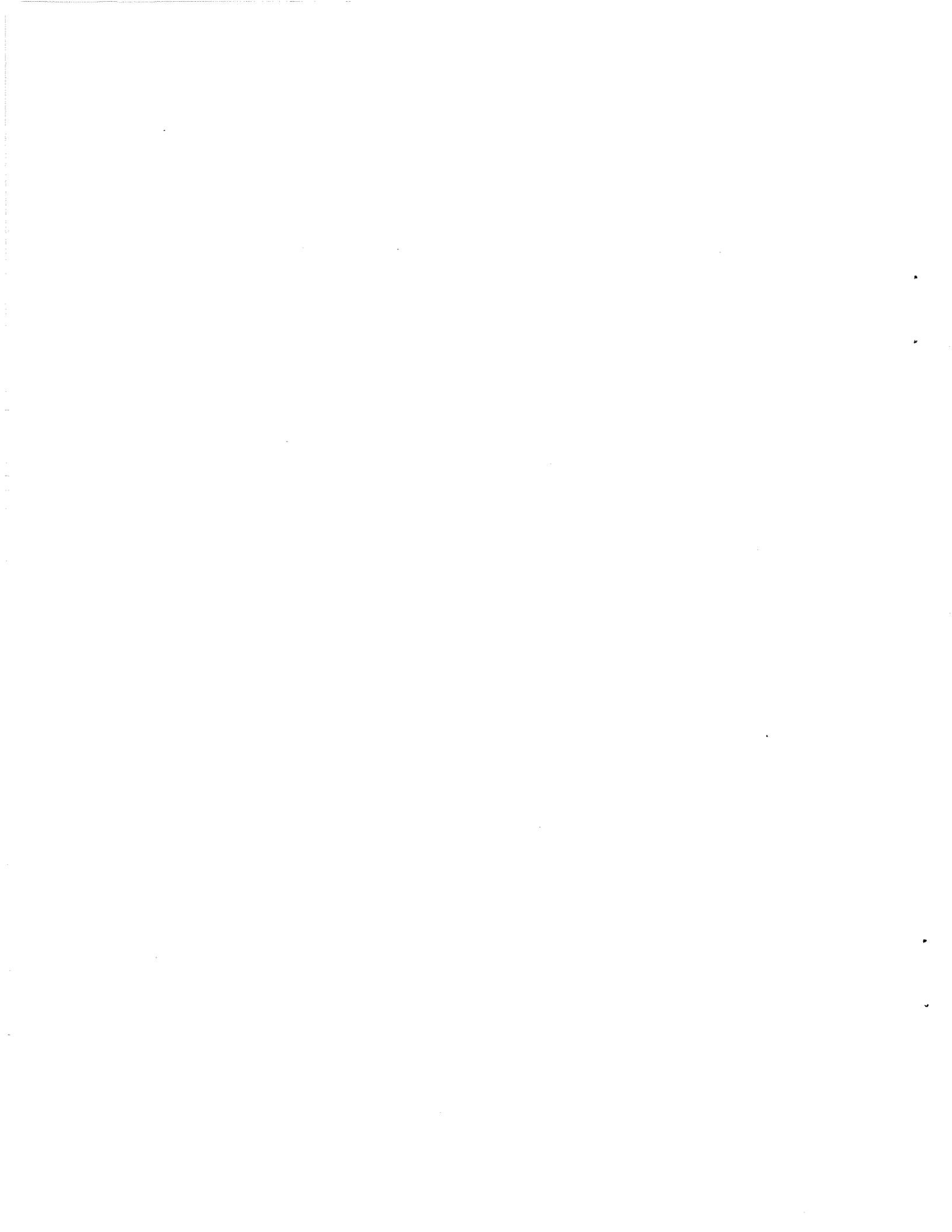

**Model 671
Spectroscopy Amplifier
Operating and Service Manual**

**Please return to
G. Sheffer or R. Hansen**



 **EG&G INSTRUMENTS**
QUALITY THAT
TOUCHES THE UNIVERSE

MODEL NO. 671

SERIAL NO. 446

This instrument has undergone a complete program of inspection and test and has been demonstrated to meet its published specifications.

TECHNICIAN BJS

DATE 2-22-00

ASSET#15352

 **EG&G INSTRUMENTS**
QUALITY THAT
TOUCHES THE UNIVERSE

MODEL NO. 671

SERIAL NO. 440

This instrument has undergone a complete program of inspection and test and has been demonstrated to meet its published specifications.

TECHNICIAN BJS

DATE 1-26-00

ASSET#15351

Model 671 Spectroscopy Amplifier Operating and Service Manual

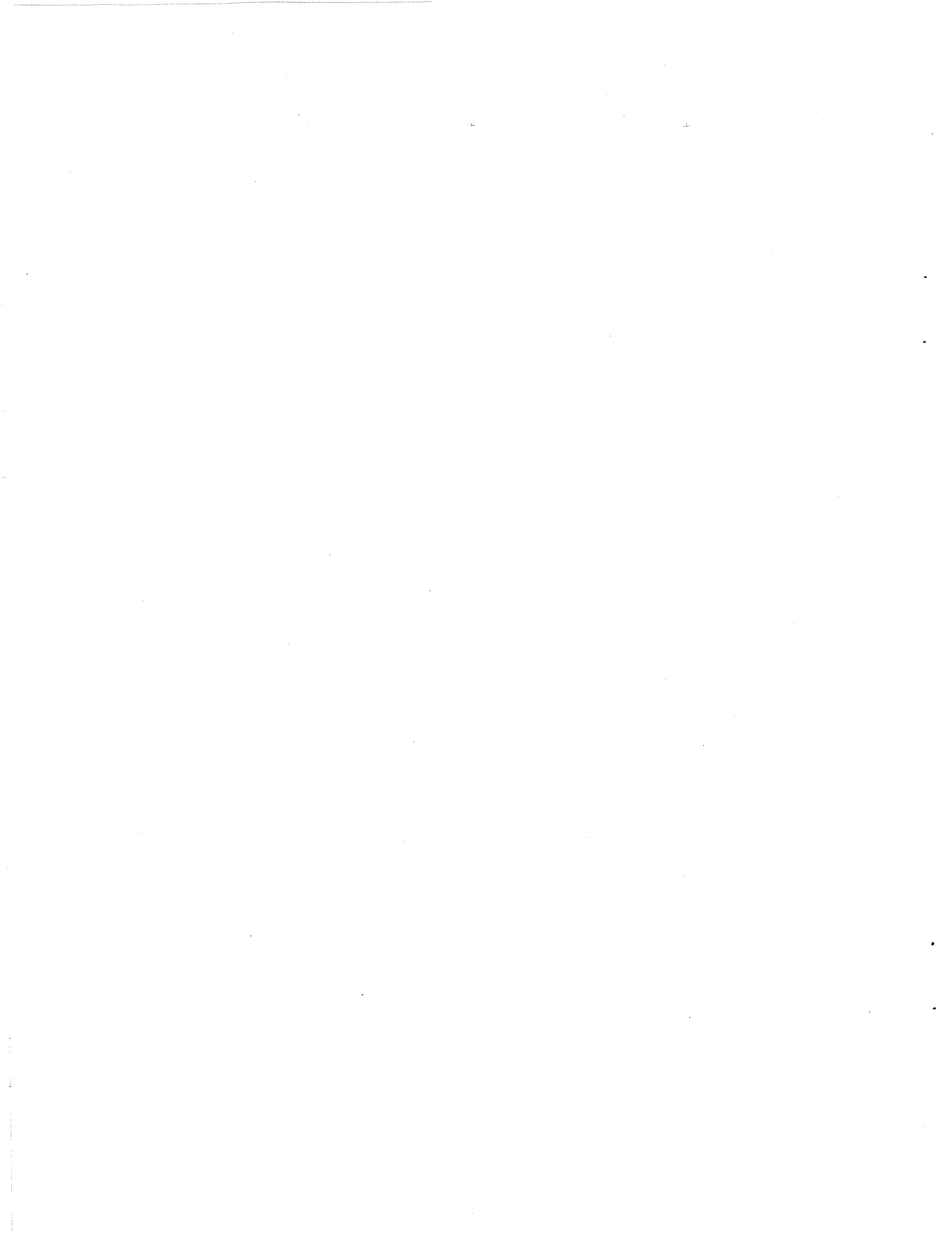

CONTENTS

	Page
WARRANTY	v
PHOTOGRAPHS	vi
1. DESCRIPTION	1
1.1. General	1
2. SPECIFICATIONS	3
2.1. Performance	3
2.2. Controls and Indicators	4
2.3. Inputs	4
2.4. Outputs	5
2.5. Electrical and Mechanical	5
3. INSTALLATION	6
3.1. Power Connection	6
3.2. Preamplifier Connection	6
3.3. Pulsed Reset Preamplifiers and INH IN Connection	6
3.4. Connection of Test Pulse Generator	6
3.5. Shaping Considerations	6
3.6. Linear Output Connections	7
3.7. Pile-Up Rejection Using PUR Output	7
3.8. Livetime Correction Using Busy Output	7
3.9. Input Count-Rate Using CRM Output	7
4. OPERATION	8
4.1. Initial Testing and Observation of Pulse Waveforms	8
4.2. Standard Setup Procedures	8
4.3. Pole-Zero Adjustments for Resistive-Feedback Preamplifier	8
4.4. Baseline Restorer (BLR) Setting	10
4.5. Internal Controls	11
4.6. Differential Input Mode	11
4.7. System Throughput	12
4.8. Charge Collection or Ballistic Deficit Effects	13
4.9. Pile-Up Rejector (PUR) and Livetime Corrector	14
4.10. Operation with Semiconductor Detectors	15
4.11. Operation in Spectroscopy Systems	17
4.12. Other Experiments	18
5. CIRCUIT DESCRIPTION	22
5.1. Introduction	22
5.2. Input Polarity and NORM/OFF Switch	22
5.3. Differential Input Amplifier Stage	22
5.4. Differentiator and Fine Gain Stage	22
5.5. Coarse Gain Stages	22
5.6. Gain Dc Stabilizer	22
5.7. Integrator Stages	23
5.8. Unipolar Output Stage	23
5.9. Bipolar Output Stage	23
5.10. Gated Baseline Restorer	23
5.11. Slow Discriminators	23
5.12. Fast Differentiator and Amplifier	23
5.13. Fast Discriminator	23
5.14. Pile-Up Inspector	23

6. MAINTENANCE	25
6.1. Test Equipment Required	25
6.2. Pulser Test	25
6.3. Suggestions for Troubleshooting	26
6.4. Factory Repair	26
6.5. Tabulated Test Point Voltages	26

Functional Block Diagram of 671

Schematics 742760 (1 thru 5 of 5)

ILLUSTRATIONS

Fig. 1.1. Gaussian, Triangular, and Bipolar Output Pulse Shapes for a 2- μ s Shaping Time	1
Fig. 1.2. Resolution and Peak Position Stability as a Function of Counting Rate	1
Fig. 1.3. Demonstration of the Effectiveness of the Pile-Up Rejector in Suppressing the Pile-Up Spectrum	2
Fig. 4.1. Typical Effects of Shaping-Time Selection on Output Waveforms	8
Fig. 4.2. Typical Gamma Spectroscopy System	8
Fig. 4.3. Typical Waveforms Illustrating Pole-Zero Adjustment Effects	9
Fig. 4.4. Pole-Zero Adjustment Using a Square Wave Input to the Preamplifier	10
Fig. 4.5. Position of Internal Controls	11
Fig. 4.6. Plot of Normalized Output Rate as a Function of Normalized Input Rate for Spectrometers with Simple Deadtime	12
Fig. 4.7. Plot of the Unpile-Up Amplifier Output Rate as a Function of Input Rate for Six Values of Shaping Time Constants	13
Fig. 4.8. Charge Collection Effect Waveforms	13
Fig. 4.9. Charge Collection Effect Spectrum	14
Fig. 4.10. Energy Resolution FWHM as a Function of Amplifier Shaping Time Constant	14
Fig. 4.11. Block Diagram for a Gamma-Ray Spectroscopy System with Pile-Up Rejection and Livetime Correction	15
Fig. 4.12. System for Measuring Amplifier and Detector Noise Resolution	15
Fig. 4.13. Noise as a Function of Bias Voltage	16
Fig. 4.14. System for Measuring Resolution with a Pulse Height Analyzer	16
Fig. 4.15. System for Detector Current and Voltage Measurements	17
Fig. 4.16. Silicon Detector Back Current vs Bias Voltage	17
Fig. 4.17. System for High-Resolution Alpha-Particle Spectroscopy	18
Fig. 4.18. System for High-Resolution Gamma Spectroscopy	18
Fig. 4.19. Scintillation-Counter Gamma Spectroscopy System	18
Fig. 4.20. High-Resolution X-Ray Energy Analysis System Using a Proportional Counter	19
Fig. 4.21. General System Arrangement for Gating Control	19
Fig. 4.22. Gamma-Ray Charged-Particle Coincidence Experiment	20
Fig. 4.23. Gamma-Ray Pair Spectroscopy	20
Fig. 4.24. Gamma-Gamma Coincidence Experiment	21
Fig. 5.1. Timing Relations in the 671 Amplifier and Pile-Up Rejector	24
Fig. 6.1. Circuit Used to Measure Nonlinearity	25

Standard Warranty

for
EG&G ORTEC Instruments

EG&G ORTEC warrants that the items will be delivered free from defects in material or workmanship. EG&G ORTEC makes no other warranties, express or implied, and specifically **NO WARRANTY OF MERCHANTABILITY OR FITNESS FOR A PARTICULAR PURPOSE.**

EG&G ORTEC's exclusive liability is limited to repairing or replacing at EG&G ORTEC's option, items found by EG&G ORTEC to be defective in workmanship or materials within **one year** from the date of delivery. EG&G ORTEC's liability on any claim of any kind, including negligence, loss, or damages arising out of, connected with, or from the performance or breach thereof, or from the manufacture, sale, delivery, resale, repair, or use of any item or services covered by this agreement or purchase order, shall in no case exceed the price allocable to the item or service furnished or any part thereof that gives rise to the claim. In the event EG&G ORTEC fails to manufacture or deliver items called for in this agreement or purchase order, EG&G ORTEC's exclusive liability and buyer's exclusive remedy shall be release of the buyer from the obligation to pay the purchase price. In no event shall EG&G ORTEC be liable for special or consequential damages.

Quality Control

Before being approved for shipment, each EG&G ORTEC instrument must pass a stringent set of quality control tests designed to expose any flaws in materials or workmanship. Permanent records of these tests are maintained for use in warranty repair and as a source of statistical information for design improvements.

Repair Service

If it becomes necessary to return this instrument for repair, it is essential that Customer Services be contacted in advance of its return so that a Return Authorization Number can be assigned to the unit. Also, EG&G ORTEC must be informed, either in writing, by telephone [(423) 482-4411], or by facsimile transmission [(423) 483-0396], of the nature of the fault of the instrument being returned and of the model, serial, and revision ("Rev" on rear panel) numbers. Failure to do so may cause unnecessary delays in getting the unit repaired. The EG&G ORTEC standard procedure requires that instruments returned for repair pass the same quality control tests that are used for new-production instruments. Instruments that are returned should be packed so that they will withstand normal transit handling and must be shipped **PREPAID** via Air Parcel Post or United Parcel Service to the nearest EG&G ORTEC repair center. The address label and the package should include the Return Authorization Number assigned. Instruments being returned that are damaged in transit due to inadequate packing will be repaired at the sender's expense, and it will be the sender's responsibility to make claim with the shipper. Instruments not in warranty will be repaired at the standard charge unless they have been grossly misused or mishandled, in which case the user will be notified prior to the repair being done. A quotation will be sent with the notification.

Damage in Transit

Shipments should be examined immediately upon receipt for evidence of external or concealed damage. The carrier making delivery should be notified immediately of any such damage, since the carrier is normally liable for damage in shipment. Packing materials, waybills, and other such documentation should be preserved in order to establish claims. After such notification to the carrier, please notify EG&G ORTEC of the circumstances so that assistance can be provided in making damage claims and in providing replacement equipment, if necessary.

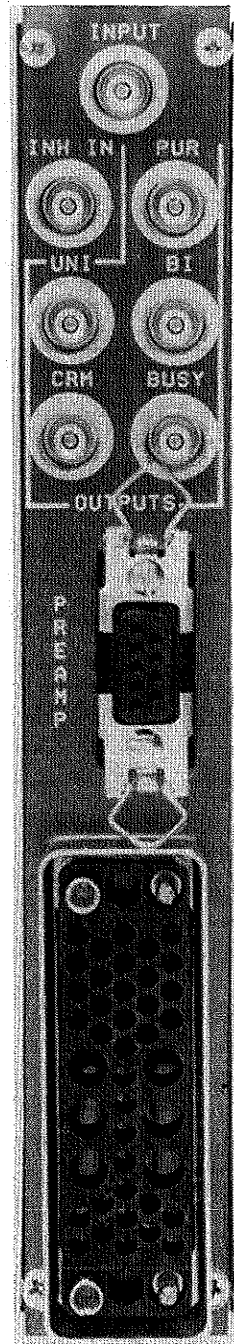
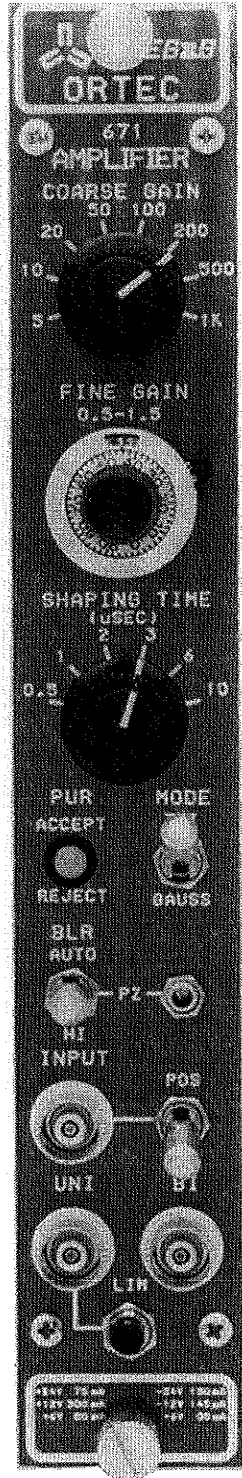

EG&G ORTEC MODEL 671 SPECTROSCOPY AMPLIFIER

1. DESCRIPTION

1.1. GENERAL

The EG&G ORTEC Model 671 high-performance, energy spectroscopy amplifier is ideally suited for use with germanium, silicon surface-barrier, and Si(Li) detectors. It can also be used with scintillation detectors and proportional counters. The Model 671 input accepts either positive or negative polarity signals from a detector preamplifier and provides a positive 0 to 10-V output signal suitable for use with single-channel or multichannel pulse height analyzers. Its gain is continuously variable from 2.5 to 1500.

Automation of critical adjustments makes the 671 easy to set up with any detector, while minimizing the required operator expertise.

A front-panel switch on the Model 671 provides the choice of either a triangular or a Gaussian pulse shape on the UNI output connector (Fig. 1.1). The noise performance of the triangular pulse shape is equivalent to a Gaussian pulse shape having a 17% longer shaping time constant. In applications where the series noise component is dominant, and the pile-up rejector is utilized, the triangular shape will generally offer the same deadtime and slightly lower noise than the Gaussian pulse shape. A front-panel switch permits selection of the optimum shaping time constant for each detector and application. Six time constants in the range of 0.5 to 10 μ s, and the TRI/GAUSS switch combine to offer 12 different shaping times. A bipolar output is also provided for measurements requiring zero cross-over timing.

To minimize spectrum distortion at medium and high counting rates (Fig. 1.2), the unipolar output incorporates a high-performance, gated, baseline restorer with several levels of automation. Automatic positive

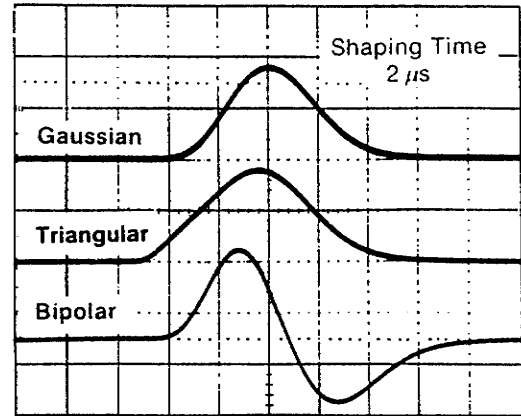

Fig. 1.1. Gaussian, Triangular, and Bipolar Output Pulse Shapes for a 2- μ s Shaping Time. Vertical scale, 5 V per division; horizontal scale, 2 μ s per division.

and negative noise discriminators ensure that the baseline restorer operates only on the true baseline between pulses in spite of changes in the noise level. No operator adjustment of the baseline restorer is needed when changes are made in the gain, the shaping time constant, or the detector characteristics. Negative overload recovery from the reset pulses generated by transistor-reset preamplifiers and pulsed optical feedback preamplifiers is also handled automatically. A monitor circuit gates off the baseline restorer and provides a reject signal for a multichannel analyzer until the baseline has safely recovered from the overload.

Several operating modes are selectable for the baseline restorer. For making a PZ adjustment, the PZ position is selected. This position can also be used

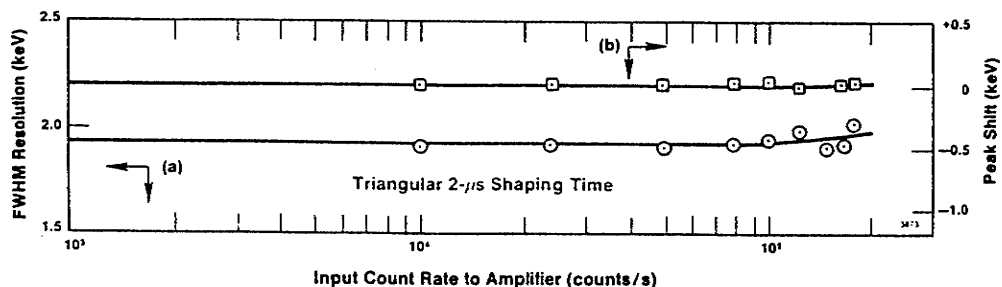

Fig. 1.2. (a) Resolution and (b) Peak Position Stability as a Function of Counting Rate. See specifications for spectrum broadening and spectrum shift.

where the slowest baseline restorer rate is desired. For situations where low-frequency noise interference is a problem, the HIGH rate can be chosen. On detectors where perfect PZ cancellation is impossible, the AUTO baseline restorer rate provides the optimum performance at both low and high counting rates.

A front-panel limit (LIM) push button is included with the unipolar output to facilitate monitoring the accuracy of the PZ adjustment on an oscilloscope. When pressed, this button inserts a diode limiter in series with the unipolar output connector. This prevents overload distortions in the oscilloscope when using the more sensitive amplitude scales required for observing the PZ adjustment.

An efficient pile-up rejector is incorporated in the 671 Spectroscopy Amplifier. It provides an output logic pulse for the associated multichannel analyzer to suppress the spectral distortion caused by pulses piling up on each other at high counting rates (Fig. 1.3). The fast amplifier in the pile-up rejector includes a gated baseline restorer with its own automatic noise discriminator. A multicolor pile-up rejector LED on the front panel indicates the throughput efficiency of the amplifier. At low counting rates the LED flashes green. The LED turns yellow at moderate counting rates and red when pulse pile-up losses are >70%.

When long connecting cables are used between the detector preamplifier output and the amplifier input, noise induced in the cable by the environment can be a problem. The Model 671 provides two solutions. For

low to moderate interference frequencies the differential input mode can be used with paired cables from the preamplifier to suppress the induced noise. At high frequencies a common mode rejection transformer built into the 671 input reduces noise pick-up. The transformer is particularly effective in eliminating interference from the display raster generators in personal computers.

All toggle switches on the front panel lock to prevent accidental changes in the desired settings.

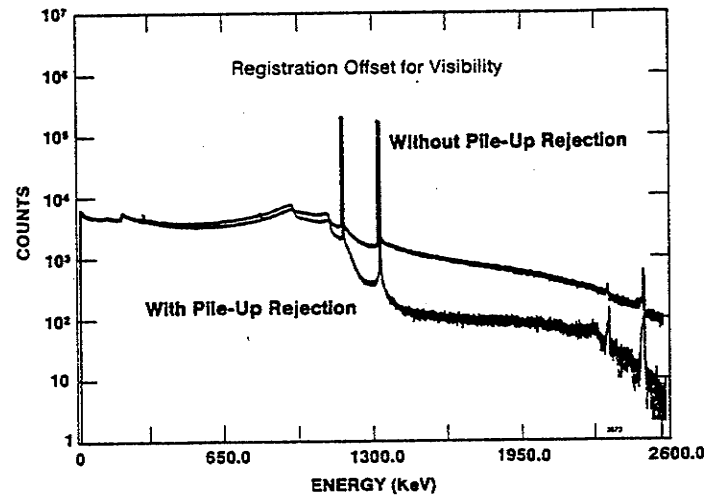

Fig. 1.3. Demonstration of the Effectiveness of the Pile-Up Rejector in Suppressing the Pile-Up Spectrum. See Pulse Pile-Up Rejector specification.

2. SPECIFICATIONS*

2.1. PERFORMANCE

Note: Unless otherwise stated, performance specifications are measured on the unipolar output with 2- μ s Gaussian shaping and the AUTO BLR mode.

GAIN RANGE Continuously adjustable from 2.5 to 1500. Gain is the product of the COARSE and FINE GAIN controls.

UNIPOLAR PULSE SHAPES Switch selection of a nearly triangular pulse shape or a nearly Gaussian pulse shape at the UNI output (Fig. 1.1, Table 2.1).

BIPOLAR OUTPUT PULSE SHAPE Rise of the bipolar output pulse from 0.1% to maximum amplitude is 1.65 times selected SHAPING TIME. Zero cross-over of the bipolar output pulse delayed from the maximum amplitude of Gaussian unipolar output by 0.33 times selected SHAPING TIME.

INTEGRAL NONLINEARITY (UNI Output)

$<\pm 0.025\%$ from 0 to +10 V.

NOISE Equivalent input noise $<5.0 \mu\text{V rms}$ for gains >100 , and $<4.5 \mu\text{V rms}$ for gains >1000 .

TEMPERATURE COEFFICIENT (0 to 50°C)

Unipolar Output $<\pm 0.005\%/^\circ\text{C}$ for gain, and $<\pm 7.5 \mu\text{V}/^\circ\text{C}$ for dc level.

Bipolar Output $<\pm 0.007\%/^\circ\text{C}$ for gain, and $<\pm 30 \mu\text{V}/^\circ\text{C}$ for dc level.

WALK Bipolar zero cross-over walk is $<\pm 3 \text{ ns}$ over a 50:1 dynamic range.

OVERLOAD RECOVERY Unipolar and bipolar outputs recover to within 2% of the rated output from a X1000

overload in 2.5 non-overloaded pulse widths using maximum gain.

SPECTRUM BROADENING† (Fig. 1.2) Typically $<8\%$ broadening of the FWHM for counting rates up to 100,000 counts per second (counts/s), and $<15\%$ broadening for counting rates up to 200,000 counts/s. Measured on the 1.33-MeV gamma-ray line from a ^{60}Co radioactive source under the following conditions: 10% efficiency EG&G ORTEC GAMMA-X PLUS detector, 8.5-V amplitude for the 1.33-MeV gamma ray on the unipolar output.

SPECTRUM SHIFT† (Fig. 1.2) Peak position typically shifts $<\pm 0.018\%$ for counting rates up to 100,000 counts/s, and $<\pm 0.05\%$ for counting rates up to 200,000 counts/s. Measured on the 1.33-MeV line under conditions specified for SPECTRUM BROADENING.

DIFFERENTIAL INPUT Differential nonlinearity $<\pm 0.012\%$ from -9 V to +9 V. Maximum input $\pm 10 \text{ V}$ (dc plus signal). Common mode rejection ratio >1000 .

PULSE PILE-UP REJECTOR

Threshold Automatically set just above noise level on fast amplifier signal. Independent of slow amplifier BLR threshold.

Minimum Detectable Signal Limited by detector and preamplifier noise characteristics.

Pulse Pair Resolution Typically 500 ns. Measured using the ^{60}Co 1.33-MeV gamma ray under the following conditions: 10% efficiency germanium detector, 4 V amplitude for the 1.33-MeV gamma ray at the unipolar output, 50,000 counts/s.

*Specifications subject to change without notice.

†Results may not be reproducible if measured with a detector producing a large number of slow-risetime pulses or having quality inferior to the specified detector.

Table 2.1. Unipolar Pulse Shape Parameters for the Triangular and Gaussian Pulse Shapes

Time Interval	Shaping Time Multiplier ^a	
	Triangular	Gaussian
From start of input pulse to maximum amplitude of unipolar output pulse	2.6	2.8
Rise of output pulse from 0.1% to maximum amplitude	2.4	2.0
Width of output pulse at 50% of maximum amplitude	2.5	2.0
Width of output pulse at 1% of maximum amplitude	5.6	5.0
Width of output pulse at 0.1% of maximum amplitude	6.9	6.3

^aTime interval equals the selected front-panel SHAPING TIME multiplied by the Shaping Time Multiplier.

2.2. CONTROLS AND INDICATORS

FINE GAIN Front-panel, 10-turn precision potentiometer with locking, graduated dial provides continuously variable, direct reading, gain factor from 0.5 to 1.5.

COARSE GAIN Front-panel, eight-position switch selects gain factors of 5, 10, 20, 100, 200, 500, and 1000.

SHAPING TIME Six-position switch on the front panel selects shaping times of 0.5, 1, 2, 3, 6, and 10 μs for the pulse-shaping filter network.

MODE Two-position locking toggle switch on the front panel selects either GAUSS (Gaussian) or TRI (Triangular) pulse shaping for the UNI (unipolar) output.

INPUT POS/NEG front-panel, two-position locking toggle switch accommodates either positive or negative input polarities.

NORM/DIFF Two-position slide switch mounted on the printed circuit board selects the normal (NORM) or differential (DIFF) input modes. In the NORM position, both front- and rear-panel INPUT connectors function as the same normal input for the preamplifier signal cable. In the DIFF mode the rear-panel INPUT connector becomes a differential ground reference input, and the front-panel INPUT remains the normal input for the preamplifier signal cable. In the DIFF mode the preamplifier signal cable is connected to the front-panel INPUT and a cable having its center conductor connected to the preamplifier ground through an impedance matching resistor is connected to the rear-panel INPUT. The impedance matching resistor must match the output impedance of the preamplifier.

BAL (Differential Input Gain Balance) A 20-turn potentiometer mounted on the PC board inside the module allows the gains of normal and differential reference inputs to be matched for maximum common mode noise rejection in DIFF mode.

PZ ADJUSTMENT 20-turn potentiometer on the front panel permits screwdriver adjustment of the PZ cancellation. The adjustment covers preamplifier exponential decay time constants from 40 μs to ∞ . For transistor reset preamplifiers or pulsed optical feedback preamplifiers, set the PZ adjustment fully counterclockwise.

LIM PUSH BUTTON Inserts a diode limiter in series with the front-panel UNI output connector. Prevents

overload distortions in the oscilloscope when observing the accuracy of the PZ adjustment on the more sensitive oscilloscope ranges.

BLR A front-panel, three-position, locking toggle switch selects the baseline restorer rate. PZ position offers lowest fixed rate for adjusting PZ cancellation. AUTO position matches the rate of the PZ position at low counting rates, but increases the restoration rate as the counting rate rises. HIGH rate position is provided for suppressing low-frequency interference.

PUR ACCEPT/REJECT LED Multicolor LED indicates percentage of pulses rejected because of pulse pile-up. LED appears green for 0—40%, yellow for 40—70%, and red for >70% rejection.

2.3. INPUTS

INPUT (Front Panel) BNC connector accepts preamplifier signals of either polarity with risetimes less than the selected SHAPING TIME, and exponential decay time constants from 40 μs to ∞ . For the NEG INPUT switch setting, the input impedance is 1000 Ω on a coarse gain of 5, and 465 Ω at coarse gain settings ≥ 10 . For the POS INPUT switch setting, the input impedance is 2000 Ω for a coarse gain of 5, and 1460 Ω for coarse gains ≥ 10 . Input is dc-coupled, and protected to ± 25 V.

INPUT (Rear Panel) BNC connector. Identical to front-panel INPUT when PWB-mounted NORM/DIFF slide switch is in the NORM position. When operating in the differential input mode with the slide switch set to DIFF, the rear-panel INPUT is used for the preamplifier ground reference connection. For the DIFF and POS INPUT switch settings, the input impedance is 1000 Ω on a coarse gain of 5, and 465 Ω at coarse gain settings ≥ 10 . For the DIFF and NEG INPUT switch settings, the input impedance is 2000 Ω for a coarse gain of 5, and 1460 Ω for coarse gains ≥ 10 . Input dc-coupled; protected to ± 25 V.

INH IN Rear-panel BNC inhibit input connector accepts reset signals from transistor reset preamplifiers or pulsed optical feedback preamplifiers. Positive NIM standard logic pulses or TTL levels can be used. Logic is selectable as active high or active low via a printed circuit board jumper. Inhibit input initiates the protection against distortions caused by the preamplifier reset. This includes turning off the baseline restorers, monitoring the negative overload recovery at the unipolar output, and generating PUR (reject) and BUSY signals for the duration of the overload.

The PUR and BUSY logic pulses are used to prevent analysis and correct for the reset deadtime in the associated ADC or multichannel analyzer.

2.4. OUTPUTS

UNI Front- and rear-panel BNC connectors provide positive, unipolar, shaped pulses with a linear output range of 0 to +10 V. Front-panel output impedance $<1 \Omega$. Rear-panel output impedance selectable for either $<1 \Omega$ or 93Ω using a printed circuit board jumper. Outputs are dc-restored to 0 ± 5 mV and short-circuit protected.

BI Front- and rear-panel BNC connectors provide bipolar shaped pulses with the positive lobe leading. The linear output range is 0 to ± 10 V. Front-panel output impedance $<1 \Omega$. Rear-panel output impedance selectable for either $<1 \Omega$ or 93Ω using a printed circuit board jumper. Baseline between pulses has a dc level of 0 ± 10 mV. Short-circuit protected.

CRM The Count Rate Meter output has a rear-panel BNC connector and provides a 250-ns-wide, +5-V logic signal for every linear input pulse that exceeds the pile-up inspector threshold. Output impedance is 50Ω .

BUSY Rear-panel BNC connector provides a +5-V logic pulse for the duration that the linear signals exceed the positive or negative baseline restorer thresholds, or the pile-up inspector threshold, or for the duration of the INH IN input signal. Useful for deadtime corrections with an associated ADC or multichannel analyzer. Positive NIM standard logic pulse is selectable as active high or active low via a printed circuit board jumper. Output impedance is 50Ω .

PUR Pile-Up Reject output is a rear-panel, BNC connector. Provides a +5-V NIM standard logic pulse when pulse pile-up is detected. Output also present for a pulsed reset preamplifier during reset, and reset overload recovery. Output pulse is selectable as active high or active low by means of a printed circuit board jumper. Output impedance is 50Ω . Used with an associated ADC or multichannel analyzer to prevent analysis of distorted pulses.

PREAMP Rear-panel standard EG&G ORTEC connector (Amphenol 17-10090) provides power for the associated preamplifier. Mates with power cords on all standard EG&G ORTEC preamplifiers.

2.5. ELECTRICAL AND MECHANICAL

POWER REQUIRED The Model 671 derives its power from a NIM Bin supplying ± 24 V and ± 12 V, such as the EG&G ORTEC Model 4001A/4002A Bin/Power Supply. The power required is +24 V at 100 mA, -24 V at 200 mA, +12 V at 325 mA, and -12 V at 180 mA.

WEIGHT

Net 1.5 kg (3.3 lb).

Shipping 3.1 kg (7.0 lb).

DIMENSIONS Standard single-width NIM module, 3.45 X 22.13 cm (1.35 X 8.714 in.) front panel per DOE/ER-457T.

3. INSTALLATION

3.1. POWER CONNECTION

The 671 operates on power that must be provided by a NIM-standard bin and power supply such as the EG&G ORTEC 4001/4002 series. Convenient test points on the power supply control panel should be used to check that the dc voltage levels are not overloaded. The bin and power supply is designed for relay rack mounting. If the equipment is rack mounted, be sure that there is adequate ventilation to prevent any localized heating of the components that are used in the 671. The temperature of the equipment mounted in racks can easily exceed the maximum limit of 50°C unless precautions are taken.

3.2. PREAMPLIFIER CONNECTION

The Preamp connector of this amplifier is directly compatible with EG&G ORTEC preamplifiers as well as with standard Aptec, Canberra, PGT, and Tennelec (serial numbers greater than 2000) preamplifiers. Preamplifier power at +24 V, -24 V, +12 V, and -12 V is available through the Preamp connector on the rear panel.

When a BNC cable longer than ten feet is used to connect the preamplifier output to the amplifier input, the characteristic impedance of the cable should match the impedance of the preamplifier output. All EG&G ORTEC preamplifiers contain series terminations that are either 93 Ω or variable; coaxial cable type RG-62/U or RG-71/U is recommended.

3.3. PULSED RESET PREAMPLIFIERS AND INH IN CONNECTION

The 671 Amplifier is directly compatible with most pulsed reset preamplifiers such as the EG&G ORTEC TRP (Transistor Reset Preamplifier) Series. The amplifier automatically senses preamplifier resets and gates off the amplifier's baseline restorer. Preamplifier inhibit signals are not required for proper amplifier operation; however, since the preamplifier resetting process is nonlinear by nature, spurious phantom peaks may show up in the spectra if the inhibit signal from the preamplifier is not used.

INH IN CONNECTION Connection of the PREAMPLIFIER INHIBIT OUT signal to the rear-panel INH IN connector will result in the system being disabled during the reset period and thus avoid spurious peaks in the spectra. Preamplifiers with an Inhibit time switch, such as EG&G ORTEC PLUS

Detector with Series 132 Preamplifier, can be set to position "1", which is the shortest preamp inhibit blocking time.

PZ SETTING The Amplifier's PZ control should be set fully counterclockwise (CCW) when used with a pulsed reset preamplifier.

3.4. CONNECTION OF TEST PULSE GENERATOR

THROUGH A PREAMPLIFIER The satisfactory connection of a test pulse generator such as the EG&G ORTEC 419 or 448 Pulse Generator or equivalent depends primarily on two considerations: the preamplifier must be properly connected to the 671 as discussed in Sections 3.2 and 3.3, and the proper signal simulation must be applied to the preamplifier. To ensure proper input signal simulation, refer to the instruction manual for the particular preamplifier being used.

DIRECTLY INTO THE 671 The EG&G ORTEC test pulse generators are designed for direct connection. When any one of these units is used, it should be terminated with a 100- Ω terminator at the amplifier input or be used with at least one of the output attenuators set at In.

SPECIAL CONSIDERATIONS FOR POLE-ZERO CANCELLATION When a tail pulser is connected directly to the amplifier input, the Pole-Zero should be adjusted. See Section 4.3 for the pole-zero adjustment. If a preamplifier is used and a tail pulser is connected to the preamplifier test input, it is not possible to adjust the pole-zero for both the preamplifier pole and the pole from the pulser tail.

3.5. SHAPING CONSIDERATIONS

The Shaping Time switch on the front panel of the 671 can be set to select time constants in steps of 0.5, 1, 2, 3, 6, and 10 μ s. Choice of triangular and Gaussian filters doubles the time constants available for optimum resolution. Triangular shaping will usually give better results. The choice of the proper shaping time is generally a compromise between operating at a shorter time constant for accommodation of high counting rates and operating with a longer time constant for a better signal-to-noise ratio. Since the full amplitude of the preamplifier output pulse must be preserved, the peaking time (measurement time) must be large compared to preamplifier output pulse risetime. The amplifier shaping time should be greater than five times the charge collection time of the detector. Use the detector manufacturer's

suggested shaping times as a starting point and adjust the shaping as your needs for resolution versus count-rate vary.

GERMANIUM DETECTORS Shaping times for high-purity germanium (HPGe) detectors will vary from 1 to 6 μs using the unipolar output, depending on the size, configuration, and charge collection time of the specific detector and preamplifier. Coaxial detectors have significant variations in charge collection times due to their large volumes. Compromises must often be made since the shaping time that will give the best resolution will usually be longer than the optimum time needed for the best throughput at high counting rates.

Planar detectors require shaping times in the range of 3 to 10 μs for optimum resolution. Lithium-drifted silicon detectors, Si(Li), have similar shaping time requirements.

SILICON CHARGED-PARTICLE DETECTORS These detectors have very fast risetimes on the order of 10 ns or less. A unipolar output and a 0.5- to 2- μs shaping time will generally provide optimum resolution.

SCINTILLATION DETECTORS The energy resolution of scintillation counters depends largely on the scintillator and photomultiplier, and therefore a shaping time of five times the decay-time constant of the scintillator is a reasonable choice. For NaI detectors that have a decay time constant of about 230 ns, the optimum shaping time is 1 μs . The bipolar output can be used to reduce overload effects and microphonics without sacrificing resolution.

GAS PROPORTIONAL COUNTERS Proportional counters have both short and long components in their charge collection times. The components typically fall in the 0.5- to 5- μs range, and lead to variable amounts of preamplifier output signal being lost as the amplifier shaping time constant is changed. Selection of longer shaping times ($>2 \mu\text{s}$) helps to minimize the problem caused by long risetimes. Due to the multiple components in the charge collection time, the correct pole-zero cancellation is not possible. This will often cause an undershoot if the unipolar output is used. Bipolar shaping can be used to reduce this effect with little change in the resolution.

3.6. LINEAR OUTPUT CONNECTIONS

Since the 671 unipolar output is normally used for spectroscopy, the 671 is designed with a great amount of flexibility for the pulse to be interfaced with an analyzer. To minimize spectrum distortion at medium

and high counting rates, the unipolar output incorporates a high-performance, gated baseline restorer with automatic setup. Automatic positive and negative noise discriminators ensure that the baseline restorer operates only on the true baseline between pulses in spite of changes in the noise level. For pulse-height analysis the unipolar output must be directly connected to the input of a multichannel analyzer.

The bipolar output, with its symmetry about the baseline, can be used for cross-over timing or may be preferred for spectroscopy when operating into ac-coupled systems at high counting rates. Typical system block diagrams for a variety of experiments are described in Section 4.

3.7. PILE-UP REJECTION USING PUR OUTPUT

The PUR (Pile-Up Reject) output on the rear panel is used at the gate or pile-up reject input of a multichannel analyzer to suppress pile-up in the recorded spectrum. The fast amplifier in the pile-up rejector includes a gated baseline restorer with an automatic noise discriminator to eliminate the need for any operator adjustments. When pileup occurs, a logic true pulse is generated which lasts until the unipolar output returns to the baseline, normally a width of six times the shaping time. If used with a pulsed reset preamplifier, this output also includes a reject during the reset and recovery interval.

3.8. LIVETIME CORRECTION USING BUSY OUTPUT

The signal from the rear-panel Busy output connector provides a nominally +5 V logic pulse for the duration that the unipolar output pulse exceeds the baseline restorer threshold or pile-up inspector threshold or when the external INH IN is true. For livetime correction, Busy should be connected to the Busy In connector on the MCA. For optimal livetime correction with EG&G ORTEC analyzers like the ADCAM[®], an internal jumper in the amplifier should be set to match the unipolar triangular or Gaussian mode. The output is internally jumper selectable as active low or active high. It is shipped as active high.

3.9. INPUT COUNT-RATE USING CRM OUTPUT

A positive logic pulse is generated for each 671 input pulse that exceeds the pile-up inspector threshold level. The pulses are available through the CRM (Count-Rate Meter) output on the rear panel and are intended for use in a count rate meter or counter to monitor the true input count-rate into the amplifier.

4. OPERATION

4.1. INITIAL TESTING AND OBSERVATION OF PULSE WAVEFORMS

Refer to Section 6 for information on testing performance and observing waveforms using a pulser. Figure 4.1 shows some typical unipolar Gaussian, unipolar triangular, and bipolar output waveforms.

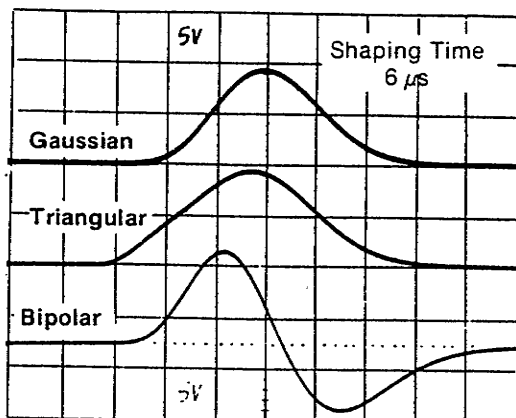
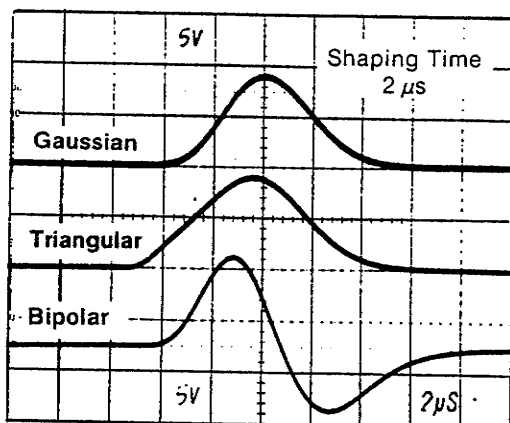
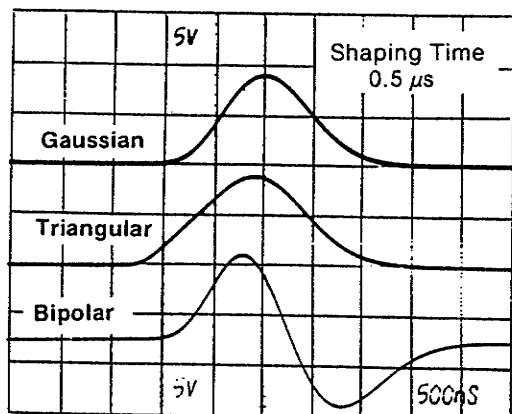

Fig. 4.1. Typical Effects of Shaping-Time Selection on Gaussian, Triangular, and Bipolar Output Waveforms.

4.2. STANDARD SETUP PROCEDURES

a. Connect the detector, preamplifier, high-voltage power supply, and amplifier into a basic system and connect the amplifier unipolar output to an oscilloscope. Connect the preamplifier power cable to the preamp power connector on the rear panel of the 671. Turn on power in the bin and power supply and allow the electronics of the system to warm up and stabilize.

A block diagram of a typical EG&G ORTEC gamma spectroscopy system is shown in Figure 4.2.

b. Set the 671 controls initially as follows:

Shaping Time	3 or 6 μ s
Mode	Triangle
Coarse Gain	20
Fine Gain	1.00
BLR	PZ
Polarity	Match preamplifier output polarity

c. Use a ^{60}Co calibration source; set about 25 cm from the active face of the detector. The unipolar output pulse from the 671 should be about 8 V, using a detector that has a preamp with a conversion gain of 300 mV/MeV.

d. Readjust the Gain control so that the higher peak from the ^{60}Co source (1.33 MeV) provides an amplifier output at about 9 V.

4.3. POLE-ZERO ADJUSTMENTS FOR RESISTIVE-FEEDBACK PREAMPLIFIER

The pole-zero adjustment is critical for good performance at high count-rates in unipolar operation and for correct operation of the BLR circuit. This adjustment should be checked carefully for the best possible results. Whenever the shaping time is

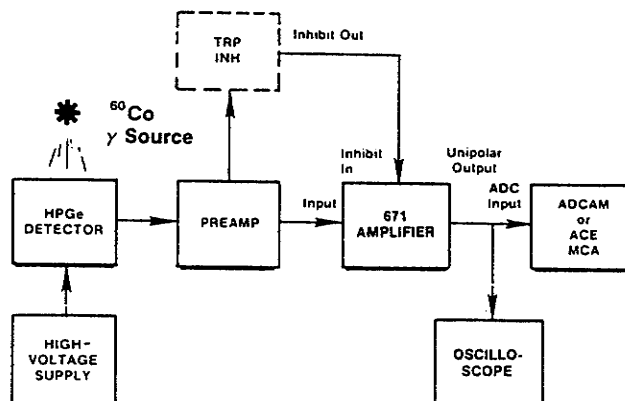

Fig. 4.2. Typical Gamma-Ray Spectroscopy System.

changed, the pole-zero must be adjusted. The bipolar output resolution is not as sensitive to misadjusted PZ, but it is important for recovery from very large overload pulses. When using a transistor reset-type preamplifier, the PZ should be set to full counterclockwise.

a. Adjust the radiation source spacing from the detector to provide a count-rate between 1 and 10 kHz.

b. Observe the unipolar output with an oscilloscope. Increase the scope input sensitivity to 20–100 mV per vertical division. Depress the front-panel LIM push button to limit the voltage applied to the oscilloscope. Adjust the PZ adjust control so that the trailing edge of the pulses returns to the baseline without overshoot or undershoot (Fig. 4.3). A slight bias toward an undershoot often gives the best results.

The oscilloscope used must be dc-coupled and must not contribute distortion in the observed waveforms. Oscilloscopes such as Tektronix models 465, 475, and 7904 will overload for a 10-V signal when the vertical sensitivity is <100 mV/Div. The LIM push-button switch inserts a diode limiter in series with the front-panel UNI output connector to prevent overloading the input of the oscilloscope.

USING SQUARE WAVE THROUGH PREAMPLIFIER TEST INPUT

A more precise pole-zero adjustment of the amplifier can be obtained by using a square wave signal as the input to the preamplifier. Many oscilloscopes include a calibration output on the front panel, and this is a good source of square wave signals at a frequency of about 1 kHz. The amplifier differentiates the signal from the preamplifier so that it generates output signals of alternate polarities on the leading and trailing edges of the square wave input signal, and these can be compared as shown in Fig. 4.4 to achieve excellent pole-zero cancellation.

Use the following procedure:

a. Remove all radioactive sources from the vicinity of the detector. Set up the system as for normal operation, including detector bias.

b. Set the amplifier controls as for normal operations; this includes gain, shaping, and input polarity.

c. Connect the source of 1 kHz square waves through an attenuator to the Test input of the preamplifier. Adjust the attenuator so that the amplifier output amplitude is 8 to 10 volts.

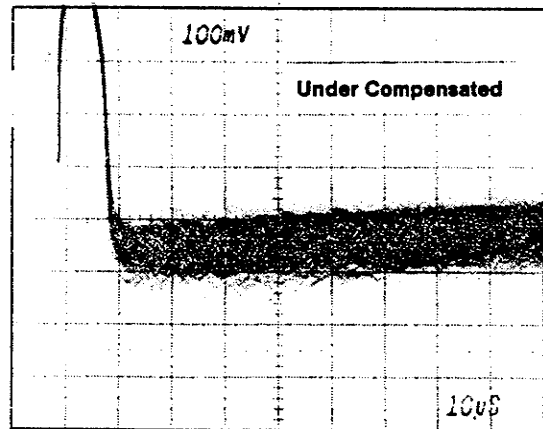
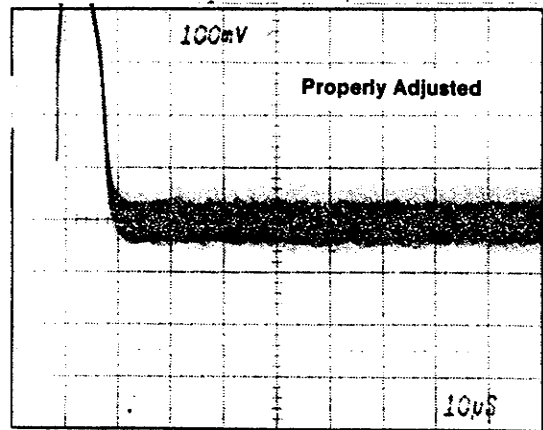
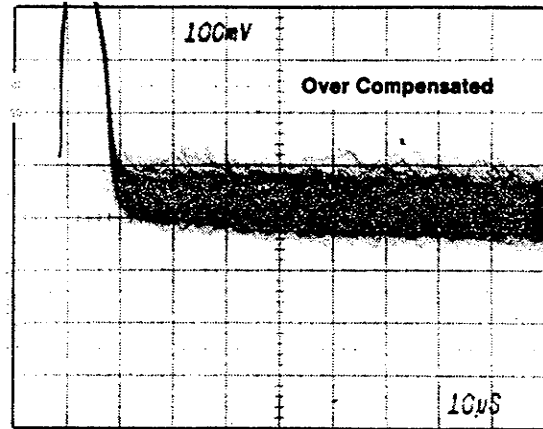

Fig. 4.3. Typical Waveforms Illustrating Pole-Zero Adjustment Effects; Oscilloscope Trigger, Busy Output, ^{60}Co Source with 1.33-MeV Peak Adjusted ~ 9 V; Count Rate, 3 kHz; Shaping Time Constant, 2 μs .

d. Observe the unipolar output of the amplifier with an oscilloscope triggered from the amplifier Busy output. Adjust the PZ control for proper response according to Fig. 4.4. Depress the LIM push button on the 671 while observing the adjustment on the oscilloscope display.

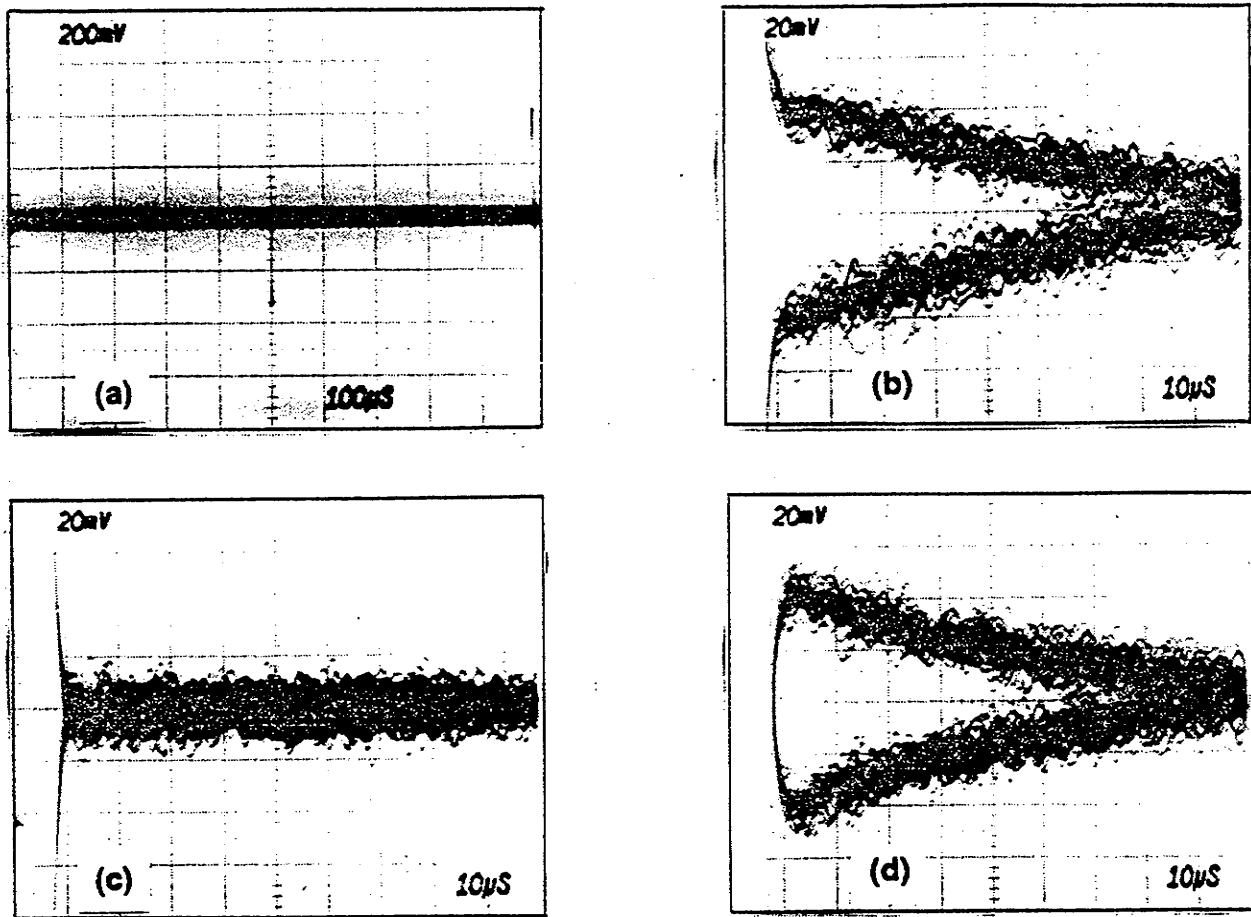

Fig. 4.4. Pole-Zero Adjustment Using a Square Wave Input to the Preamplifier. (a) PZ properly adjusted; slow trigger to separate pulses. (b) Overcompensated; fast trigger to superimpose pulses. (c) Properly adjusted; pulses superimposed. (d) Undercompensated; pulses superimposed.

Figure 4.4(a) shows the amplifier output as a series of alternate positive and negative shaped pulses. In Fig. 4(b)-(d) the oscilloscope was triggered to show both positive and negative pulses simultaneously. These pictures show more detail to aid in proper adjustment.

4.4. BASELINE RESTORER (BLR) SETTING

To minimize spectrum distortion at medium and high counting rates, the unipolar output incorporates a high-performance, gated, baseline restorer with several levels of automation. Automatic positive and negative noise discriminators ensure that the baseline restorer operates only on the true baseline between pulses in spite of changes in the noise level. No operator adjustment of the baseline restorer is needed when changes are made in the gain, the shaping time constant, or the detector characteristics. Negative overload recovery from the reset pulses generated by

transistor reset preamplifiers and pulsed optical feedback preamplifiers is also handled automatically to eliminate the need for operator adjustments. A monitor circuit gates off the baseline restorer and provides a reject signal for a multichannel analyzer until the baseline has safely recovered from the overload.

BLR RATE For making pole-zero adjustments, the PZ position is selected. This position can also be used where the slowest baseline restorer rate is desired.

With the BLR Rate set to AUTO, the BLR is automatically set for optimum performance throughout the usable input range for the shaping selected.

The HIGH rate can be used for situations where low or medium frequency noise interference is present and is independent of the counting rate. The HIGH rate setting is normally not used since there will be a small loss of resolution due to increased noise when used in high-resolution systems.

4.5. INTERNAL CONTROLS

These controls are on the printed wiring board (PWB) and can be accessed by removing the right side cover. Figure 4.5 shows the location of these controls.

NORM-DIFF Internal PWB mounted, two-position slide switch. NORM position selects single ended inputs from front-panel input or rear-panel input connectors. In the DIFF position, the front-panel input is connected to the preamplifier signal cable, and a cable connected to the preamplifier ground through an impedance matching resistor is connected to the rear-panel input.

BAL (DIFFERENTIAL INPUT GAIN BALANCE) Internal PWB 20-turn screwdriver potentiometer allows maximization of noise rejection when using the differential input mode. See Section 4.6.

UNI-OUT (UNIPOLAR Z_{out}) Jumper plug, W1, provides $Z_{out} \leq 1 \Omega$ or $\sim 93 \Omega$ for the rear-panel Unipolar output. Shipped in the 93- Ω position.

BI-OUT (BIPOLAR Z_{out}) Jumper plug, W2, provides $Z_{out} \leq 1 \Omega$ or 93Ω for the rear-panel Bipolar output. Shipped in the 93- Ω position.

BUSY/BUSY Jumper plug, W3, allows the Busy output to be a positive true or negative true logic signal. Shipped in BUSY (positive true) position.

PUR/PUR Jumper plug, W5, allows the Pile-Up Reject (PUR) output to be a positive true or negative true logic signal. Shipped in PUR (positive true) position.

INH/INH Jumper plug, W6, allows the INH IN input to accept either positive true or negative true logic signals. Shipped in INH (positive true) position.

TRI/GAUSS Jumper plug, W7, allows optimal lifetime correction when used with EG&G ORTEC analyzers like the ADCAM[®] by connecting the BUSY output to the analyzer Busy.In as described in Section 3.8. The jumper should be set to match the Unipolar Mode, TRI for Triangle and GAUSS for Gaussian. Shipped in TRI position.

4.6. DIFFERENTIAL INPUT MODE

When long connecting cables are used between the detector and preamplifier input, noise induced in the cable by the environment can be a problem. The differential input mode can be used with paired cables from the preamplifier to suppress the induced noise.

BAL (DIFFERENTIAL INPUT GAIN BALANCE) The BAL potentiometer is used to adjust the gain balance between the positive and negative inputs and to adjust the balance between the front- and rear-panel inputs

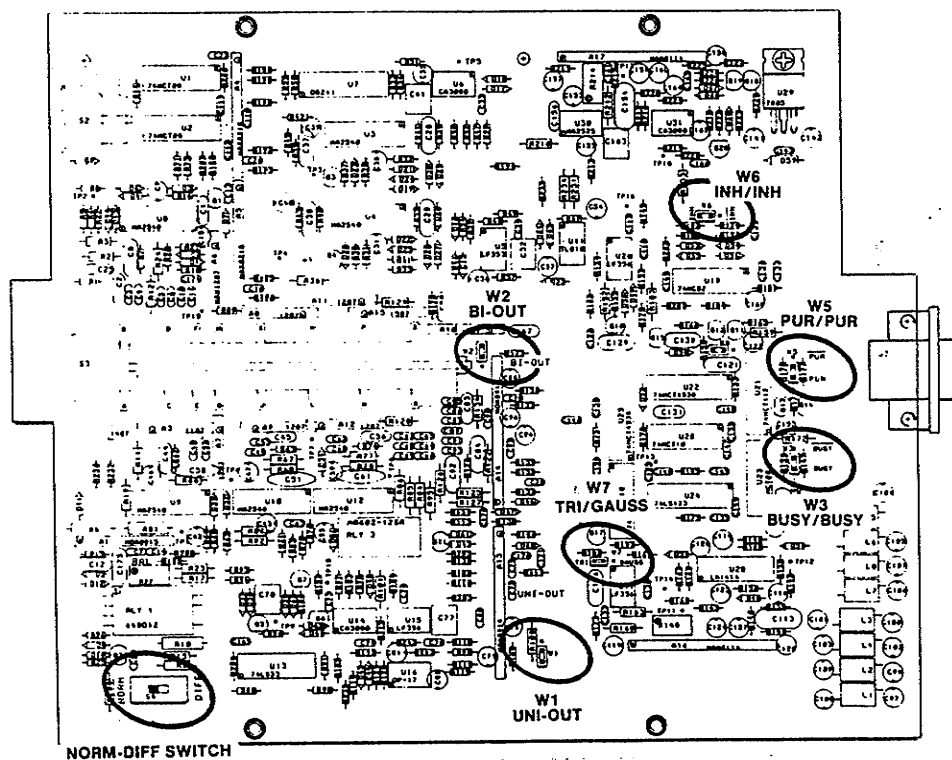

Fig. 4.5. Position of Internal Controls.

when the differential (DIFF) input mode is used. The initial adjustment of Gain Balance is made by providing the same input to both the front- and rear-panel inputs. This can be accomplished by using a BNC "T" connector to feed the input signal on the front-panel input to the rear-panel input. Set the amplifier gain to maximum. Connect an oscilloscope to the unipolar output. While observing the signal on the oscilloscope, use a small screwdriver to adjust the Gain Balance (internal adjustment has been factory set, Fig. 4.5) potentiometer until the display on the oscilloscope shows minimum signal. Remove the BNC "T" connector when the adjustment is complete, and the positive and negative gains will be matched for use with NORM input.

If the differential input mode is being used, connect the differential input cable to the input BNC connector on the rear panel. Adjust BAL potentiometer until there is minimum noise around the baseline of the output signal. If there is a problem in getting minimum noise, repeat the initial procedure with the BNC "T" and the adjustment.

DIFFERENTIAL INPUT SIGNAL The differential input signal or phantom is used only in the differential (DIFF) input mode. The normal preamp output is connected to the front-panel input with the amplifier input polarity set to match this signal. A second output cable must be added to the preamplifier with its center, signal pin connected to the preamplifier ground with the same value as the normal preamp output series resistor (usually 93.1 or 51 Ω).

Many EG&G ORTEC preamplifiers have two Energy outputs, each with a 93.1- Ω series resistor. For differential operation, one output is connected to the amplifier front-panel input. The second output is modified by connecting the preamplifier end of the series 93.1- Ω resistor to ground within the preamp (soldering may be necessary). This second output should be properly marked and connected to the rear-panel input. Both cables should be the same length and be run next to each other.

4.7. SYSTEM THROUGHPUT

To achieve the desired results in high-rate energy spectroscopy, the experimenter must consider not only the input rate, but also the unpiled-up output rate. The unpiled-up output rate is determined by the processing time of the shaping amplifier, the pile-up inspection time, and the input rate. For semi-Gaussian time-invariant filter amplifiers, the unpiled-up output rate is theoretically given by¹

$$r_o = r_i \exp(-T_D r_i) \quad (1)$$

where r_o is the unpiled-up output count rate, r_i is the input count rate, and T_D is the deadtime or effective processing time of the amplifier. The value of T_D is equal to the sum of the effective amplifier pulse width, T_w , and the time-to-peak of the amplifier output pulse, T_p . The type of deadtime in the shaping amplifier is referred to as extending deadtime since a second event arriving before the end of the initial deadtime extends the deadtime by an additional amplifier output pulse width, T_w , from the occurrence of the second pulse.

A normalized plot of Equation (1) is shown as the solid line in Fig. 4.6. The maximum mean output rate equals $1/T_D \exp(1)$ and occurs when the mean input rate equals $1/T_D$. At this maximum output rate the deadtime losses are 63.2%. For input count rates exceeding $1/T_D$ the unpiled-up output rate decreases. When using a pile-up inspection circuit, the value of T_D is given either by the sum of T_w and T_p or by the sum of T_p and the pile-up inspection time, whichever is larger.

Spectroscopy systems also have a deadtime that is caused by the digitizing time of the Analog-to-Digital Converter (ADC). This deadtime is a non-extending deadtime since events arriving during the digitizing time are ignored. For non-extending deadtime the output rate is given by¹

$$r_o = \frac{r_i}{1 + r_i T_D} \quad (2)$$

where T_D is the digitizing time for the ADC and is designated T_M in Equation (3). This relationship is shown as the dashed line in Fig. 4.6. The maximum obtainable output count rate is $1/T_D$ and occurs at $r_i = \infty$.

When the ADC is considered as part of the spectroscopy system, the deadtimes of the amplifier and ADC are in series. The combination of the

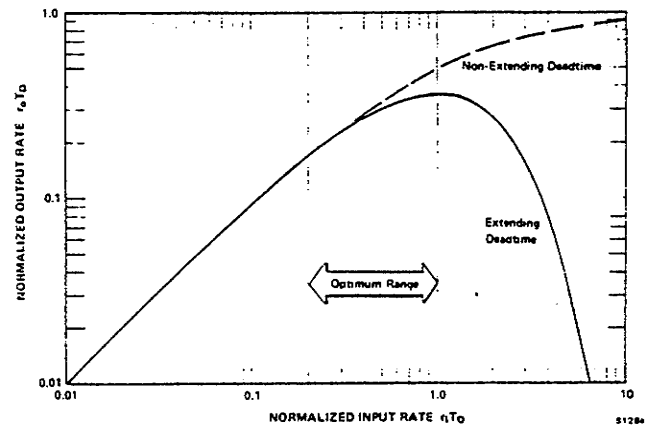

Fig. 4.6. Plot of Normalized Output Rate as a Function of Normalized Input Rate for Spectrometers with Simple Deadtime.

¹R. Jenkins, R.L. Gould, and D.A. Gedcke, *Quantitative X-Ray Spectroscopy*, Marcel and Dekker, Inc., New York, (1980).

extending deadtime of the amplifier followed by the non-extending deadtime of the ADC is given by¹

$$r_o = \frac{r_i}{\exp[r_i(T_w + T_p)] + r_i[T_M - (T_w - T_p)] U[T_M - (T_w - T_p)]} \quad (3)$$

where $U[T_M - (T_w - T_p)]$ is a unit step function that changes value from 0 to 1 when T_M is greater than $(T_w - T_p)$. Equation (3) reduces to Equation (1) when T_M is less than $(T_w - T_p)$.

A plot of the unpiled-up amplifier output rate as a function of input rate for six values of shaping time is shown in Fig. 4.7. The measured deadtime, T_D , is shown for each shaping time constant. The maximum value of the unpiled-up output rate increases with decreasing values of shaping time constant. A set of throughput curves will remain nearly unchanged for a given amplifier for various energy ranges, detector types, and sizes.

The advantage of shorter shaping time constants to achieve higher output count rates is clearly shown in Fig. 4.7. However, shorter time constants also result in increased noise and increased charge collection time effects. Under worst case conditions, the noise increases inversely as the square root of the ratio of shaping time constants. The total energy resolution is the noise contribution combined in quadrature with the statistical contribution of the detector at the energy of interest. Consequently, the percentage of degradation in energy resolution can be much less than the percentage increase in noise.

4.8. CHARGE COLLECTION OR BALLISTIC DEFICIT EFFECTS

Charge collection distances in large-volume HPGe detectors are often 3 cm or more, resulting in charge collection times exceeding 300 ns.^{2,3,4} These charge collection times are due to the transit time of the holes and the electrons in germanium and are not due to defects in the detector. Fig. 4.8(a) shows some typical current pulse waveforms from a 140-cm³, 28% efficient HPGe detector. These current pulse waveforms were obtained using the simple differentiation circuit shown in Fig. 4.8(b), which has a 15-ns time constant. The current pulses range in duration from 100 ns to greater than 350 ns. Pulses

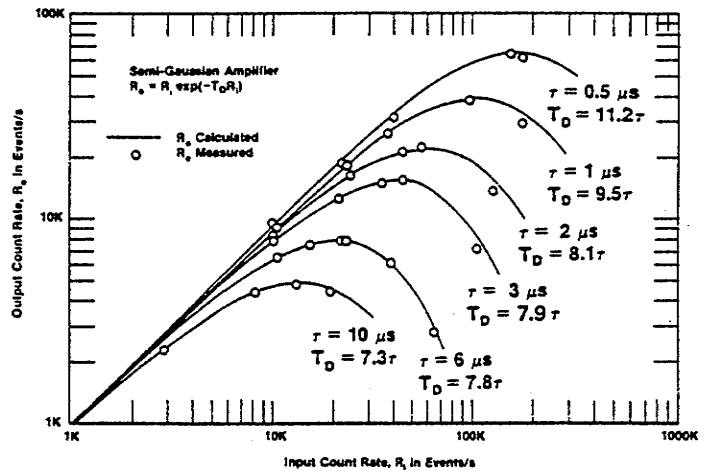
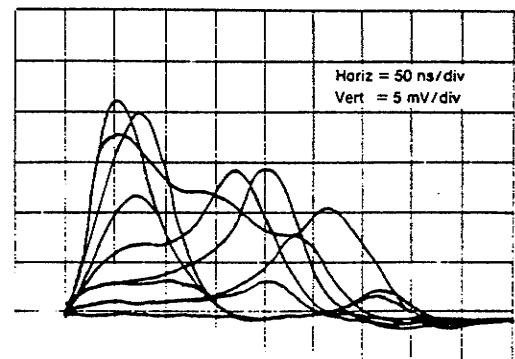
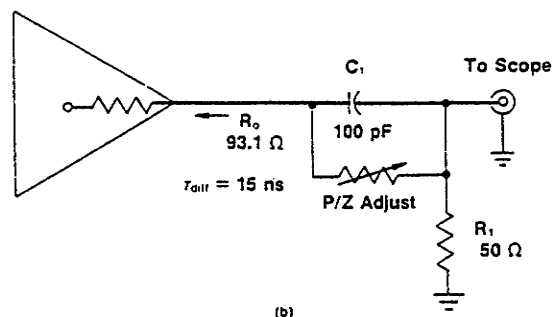

Fig. 4.7. Plot of the Unpiled-Up Amplifier Output Rate as a Function of Input Rate for Six Values of Shaping Time Constants.



(a)



(b)

Fig. 4.8. Charge Collection Effect Waveforms. (a) Typical Current Pulse Waveforms for a 28% Efficient HPGe Detector, and (b) the Simple Differentiation Circuit Used to Obtain the Current Waveforms.

having equivalent total charge but different durations produce different output pulse heights when processed by a charge-sensitive preamplifier and a semi-Gaussian filter amplifier. This results in the distortion of the spectrum in direct proportion to the pulse amplitude or energy. This distortion is most pronounced at short shaping time constants.

²E. Sakai, "Charge Collection in Coaxial Ge(Li) Detectors," *IEEE Trans. Nucl. Sci.*, NS-15, 310, (1968).

³E. Sakai, T.A. McMath, and R.G. Franks, "Further Charge Collection Studies in Coaxial Ge(Li) Detectors," *IEEE Trans. Nucl. Sci.*, NS-16, 68, (1968).

⁴T.H. Becker, E.E. Gross, and R.C. Trammell, "Characteristics of High-Rate Energy Spectroscopy Systems with Time-Invariant Filters," *IEEE Trans. Nucl. Sci.*, NS-28, 1, (1981).

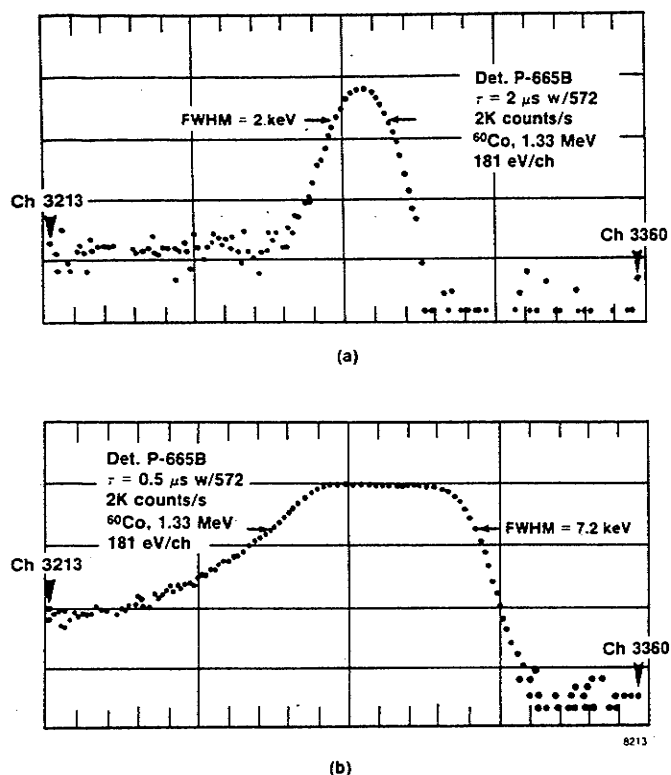

Fig. 4.9. Charge Collection Effect Spectrum. Logarithmic Display of Spectrum Taken with a 10% Efficient HPGe Detector for the 1.33-MeV ^{60}Co Line. (a) A 2- μs Shaping Time Constant and (b) a 0.5- μs Shaping Time Constant.

Figure 4.9(a) shows a portion of a spectrum obtained with a 10% efficient HPGe detector at 2- μs shaping time, using the 1.33-MeV line of ^{60}Co . An equivalent spectrum using a 0.5- μs shaping time is shown in Fig. 4.9(b) and is significantly distorted.

Charge collection time effects are of significant importance when using large-volume Ge detectors at high energy. The performance of two HPGe detectors is compared in Fig. 4.10 at two different energies. When using the 122-keV line of ^{57}Co , the principal cause of resolution degradation with decreased shaping time constant is the increase in noise. However, when using the 1.33-MeV line of ^{60}Co , the significant degradation in resolution is due to charge collection effects. The calculated resolution for the 10% detector at 1.33 MeV is shown as the dashed line in Fig. 4.10 and indicates approximately 2.0 keV FWHM at a 0.5- μs shaping time constant. The measured resolution under these test conditions was 7.2 keV, indicating that charge collection effects dominate. In Fig. 4.10, charge collection effects begin to appear at time constants less than 3 μs .

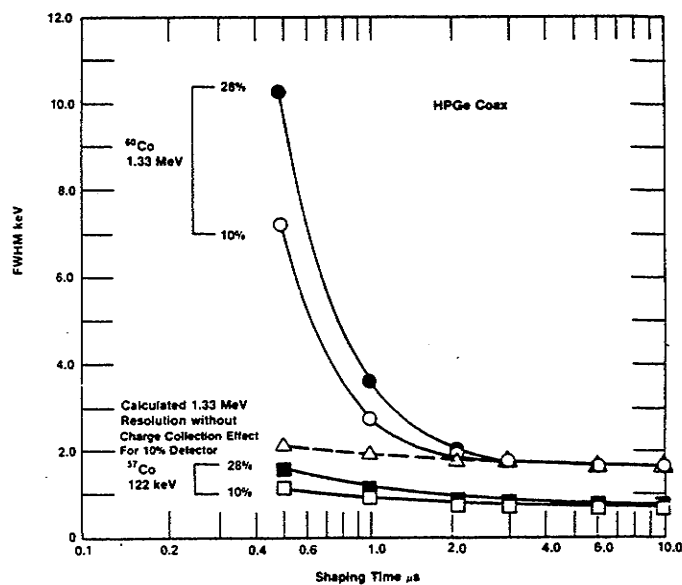

Fig. 4.10. Energy Resolution FWHM as a Function of Amplifier Shaping Time Constant for a 10% HPGe Detector and a 28% HPGe Detector for the 122-keV ^{57}Co Line and the 1.33-MeV ^{60}Co Line.

4.9. PILE-UP REJECTOR (PUR) AND LIVETIME CORRECTOR

An efficient pile-up rejector is incorporated in the amplifier to suppress the spectral distortion which is caused by pulses piling up on each other at high counting rates. High counting rate for pile-up is dependent on the dead time per pulse, T_D , and hence the selected shaping time. T_D is 9 times the front-panel shaping time, T_C . High count rate for the PUR is when the normalized count rate $R_i T_D > 0.5$, where R_i is the amplifier input rate (see Fig. 4.6). For example, for 6- μs shaping R_i is 9 kHz and for 2- μs shaping, R_i is 28 kHz. Amplifier throughput for this condition using Equation (1) in Section 4.7 is 60% of the input rate. A multicolor pile-up rejector LED is included on the front panel to indicate the throughput efficiency of the amplifier. At low counting rates (pulse pile-up losses $< 40\%$) the LED flashes with a green color. At moderate counting rates the color changes to yellow. The color changes to red at high counting rates when the pulse pile-up losses are $> 70\%$.

The fast amplifier in the pile-up rejector includes a gated baseline restorer with its own automatic noise discriminator to eliminate the need for any operator adjustments. This function is also protected against negative overloads from pulsed reset preamplifiers. The PUR (pile-up reject) output logic pulse can be used at the gate or reject input of a multichannel

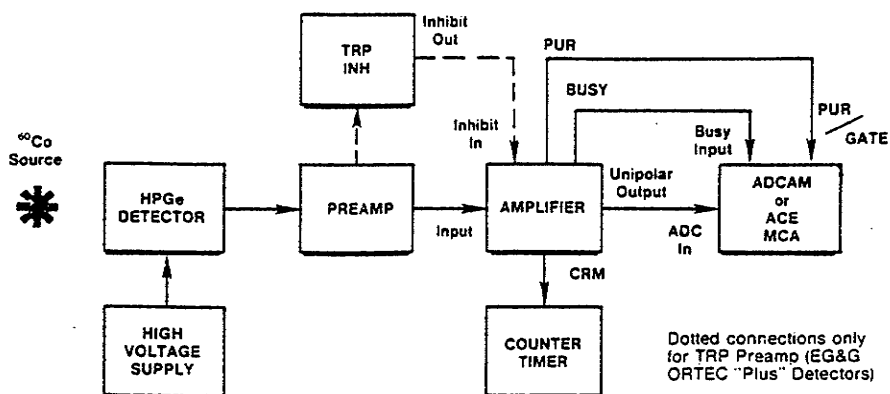

Fig. 4.11. Block Diagram for a Gamma-Ray Spectroscopy System with Pile-Up Rejection and Livetime Correction.

analyzer to suppress pile-up in the recorded spectrum.

The block diagram for a gamma-ray spectroscopy system with pile-up rejection and live time correction is shown in Fig. 4.11.

FOR A RESISTIVE FEEDBACK PREAMP, connect:

a. Inhibit pulse from PUR to ADC PUR or ADC anticoincidence input.

b. Livetime correction signal (Busy output) to the ADC Busy In.

ADDITIONAL CONNECTION FOR TRP (Transistor Reset Preamp) Shown in dotted lines.

c. Inhibit Output from TRP to the amplifier Inhibit In.

4.10. OPERATION WITH SEMICONDUCTOR DETECTORS

CALIBRATION OF TEST PULSER An EG&G ORTEC 419 Precision Pulse Generator, or equivalent, is easily calibrated so that the maximum pulse height dial reading (1000 divisions) is equivalent to a 10-MeV loss in a silicon radiation detector. The procedure is as follows:

a. Connect the detector to be used to the spectrometer system, that is, preamplifier, main amplifier, and biased amplifier.

b. Allow excitation from a source of known energy (for example, alpha particles) to fall on the detector.

c. Adjust the amplifier gain and the bias level of the biased amplifier to give a suitable output pulse.

d. Set the pulser Pulse Height control at the energy of the alpha particles striking the detector (e.g., set the dial at 547 divisions for a 5.47-MeV alpha particle energy).

e. Turn on the pulser and use its Normalize control and attenuators to set the output due to the pulser for the same pulse height as the pulse obtained in step c. Lock the Normalize control and do not move it again until recalibration is required.

The pulser is now calibrated; the Pulse Height dial reads directly in MeV if the number of dial divisions is divided by 100.

AMPLIFIER NOISE AND RESOLUTION MEASUREMENTS As shown in Fig. 4.12, a preamplifier, amplifier, pulse generator, oscilloscope, and wide-band rms voltmeter such as the Hewlett-Packard 3400A are required for this measurement. Connect a suitable capacitor to the input to simulate the detector capacitance desired. To obtain the resolution spread due to amplifier noise:

a. Measure the rms noise voltage (E_{rms}) at the amplifier output.

b. Turn on the 419 precision pulse generator and adjust the pulser output to any convenient readable voltage, E_0 , as determined by the oscilloscope.

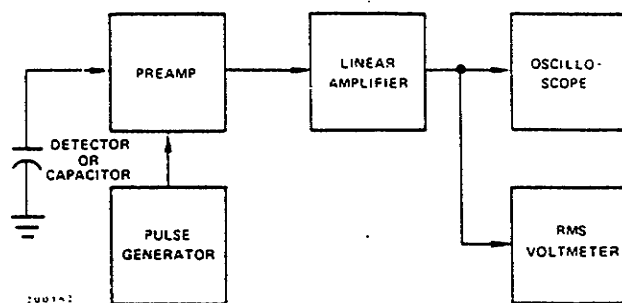

Fig. 4.12. System for Measuring Amplifier and Detector Noise Resolution.

The full-width-at-half-maximum (FWHM) resolution spread due to amplifier noise is then

$$N(\text{FWHM}) = \frac{2.35 E_{\text{rms}} E_{\text{dial}}}{E_0}$$

where E_{dial} is the pulser dial reading in MeV and 2.35 is factor for rms to FWHM. For average-responding voltmeters such as the Hewlett-Packard 400D, the measured noise must be multiplied by 1.13 to calculate the rms noise.

The resolution spread will depend on the total input capacitance, since the capacitance degrades the signal-to-noise ratio much faster than the noise.

DETECTOR NOISE-RESOLUTION MEASUREMENTS

The measurement just described can be made with a biased detector instead of the external capacitor that would be used to simulate detector capacitance. The resolution spread will be larger because the detector contributes both noise and capacitance to the input. The detector noise-resolution spread can be isolated from the amplifier noise spread if the detector capacity is known, since

$$(N_{\text{det}})^2 + (N_{\text{amp}})^2 = (N_{\text{total}})^2$$

where N_{total} is the total resolution spread and N_{amp} is the amplifier resolution spread when the detector is replaced by its equivalent capacitance.

The detector noise tends to increase with bias voltage, but the detector capacitance decreases, thus reducing the resolution spread. The overall resolution spread will depend upon which effect is dominant. Figure 4.13 shows curves of typical noise-resolution spread versus bias voltage, using data from several EG&G ORTEC silicon surface-barrier semiconductor radiation detectors.

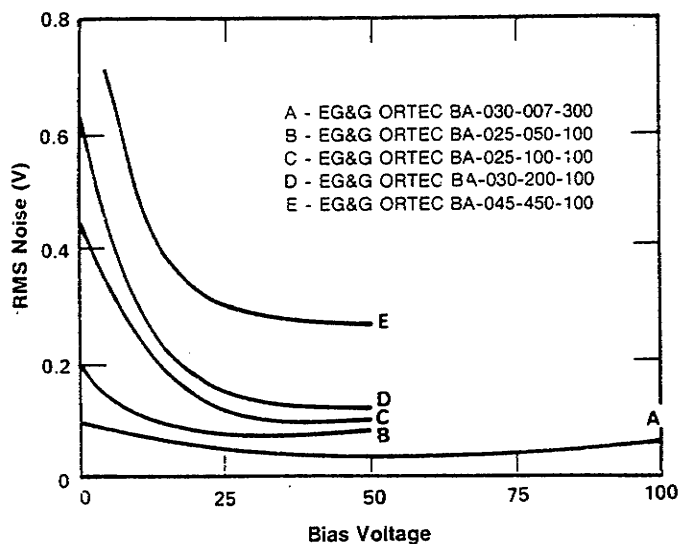

Fig. 4.13. Noise as a Function of Bias Voltage.

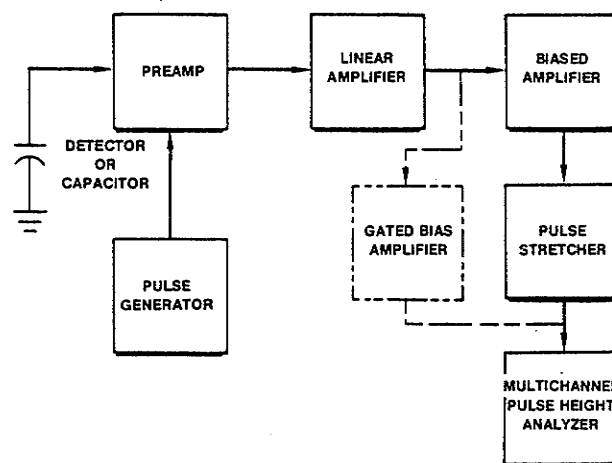

Fig. 4.14. System for Measuring Resolution with a Pulse Height Analyzer.

AMPLIFIER NOISE-RESOLUTION MEASUREMENTS USING MCA

Probably the most convenient method of making resolution measurements is with a pulse height analyzer as shown by the setup illustrated in Fig. 4.14.

The amplifier noise-resolution spread can be measured directly with a pulse height analyzer and the mercury pulser as follows:

- Select the energy of interest with an EG&G ORTEC 419 Precision Pulse Generator. Set the amplifier and biased amplifier gain and bias level controls so that the energy is in a convenient channel of the analyzer.
- Calibrate the analyzer in keV per channel, using the pulser; full scale on the pulser dial is 10 MeV when calibrated as described above.
- Obtain the amplifier noise-resolution spread by measuring the FWHM of the pulser peak in the spectrum.

The detector noise-resolution spread for a given detector bias can be determined in the same manner by connecting a detector to the preamplifier input. The amplifier noise-resolution spread must be subtracted as described in Section 4.10, "Detector Noise-Resolution Measurements." The detector noise will vary with detector size and bias conditions and possibly with ambient conditions.

CURRENT-VOLTAGE MEASUREMENTS FOR Si AND Ge DETECTORS

The amplifier system is not directly involved in semiconductor detector current-voltage measurements, but the amplifier serves to permit noise monitoring during the setup. The detector noise measurement is a more sensitive method of determining the maximum detector

voltage than a current measurement and should be used because the noise increases more rapidly than the reverse current at the onset of detector breakdown. Make this measurement in the absence of a source.

Figure 4.15 shows the setup required for current-voltage measurements. An EG&G ORTEC 428 Bias Supply is used as the voltage source. Bias voltage should be applied slowly and reduced when noise increases rapidly as a function of applied bias. Figure 4.16 shows several typical current-voltage curves for EG&G ORTEC silicon surface-barrier detectors.

When it is possible to float the microammeter at the detector bias voltage, the method of detector current measurement shown by the dashed lines in Fig. 4.15 is preferable. The detector is grounded as in normal operation, and the microammeter is connected to the current monitoring jack on the 428 detector bias supply.

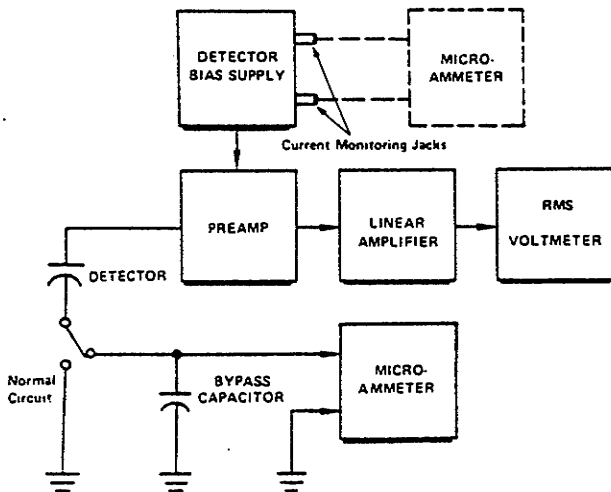

Fig. 4.15. System for Detector Current and Voltage Measurements.

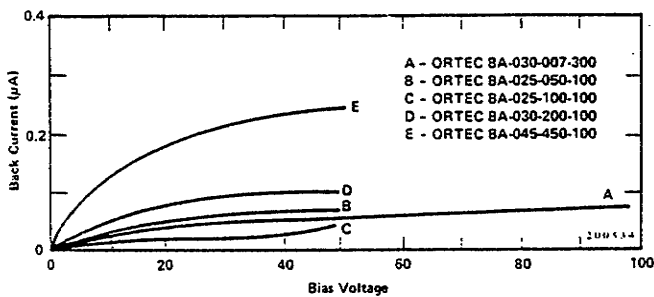

Fig. 4.16. Silicon Detector Back Current vs Bias Voltage.

4.11. OPERATION IN SPECTROSCOPY SYSTEMS

HIGH-RESOLUTION ALPHA-PARTICLE SPECTROSCOPY SYSTEM The block diagram of a high-resolution spectroscopy system for measuring natural alpha particle radiation is shown in Fig. 4.17. Since natural alpha radiation occurs only above several MeV, an EG&G ORTEC 444 Biased Amplifier is used to suppress the unused portion of the spectrum; the same result can be obtained by using digital suppression on the MCA in many cases. Alpha-particle resolution is obtained in the following manner:

- Use appropriate amplifier gain and minimum biased amplifier gain and bias level. Accumulate the alpha peak in the MCA.
- Slowly increase the bias level and biased amplifier gain until the alpha peak is spread over 5 to 10 channels and the minimum- to maximum-energy range desired corresponds to the first and last channels of the MCA.
- Calibrate the analyzer in keV per channel using the pulser and the known energy of the alpha peak (see Section 4.10, "Calibration of Test Pulser") or two known energy alpha peaks.

- Calculate the resolution by measuring the number of channels at the FWHM level in the peak and converting this to keV.

HIGH-RESOLUTION GAMMA-RAY SPECTROSCOPY SYSTEM A high-resolution gamma-ray spectroscopy system block diagram is shown in Fig. 4.18. Although a biased amplifier is not shown (an analyzer with more channels being preferred), it can be used if the only analyzer available has fewer channels and only higher energies are of interest.

When germanium detectors that are cooled by a liquid nitrogen cryostat are used, it is possible to obtain resolutions from about 1 keV FWHM up to 4 keV (depending on the energy of the incident radiation and the size and quality of the detector). Reasonable care is required to obtain such results. Some guidelines for obtaining optimum resolution are:

- Keep interconnection capacities between the detector and preamplifier to an absolute minimum (no long cables).
- Keep humidity low near the detector-preamplifier junction.
- Operate the amplifier with the shaping time that provides the best signal-to-noise ratio.

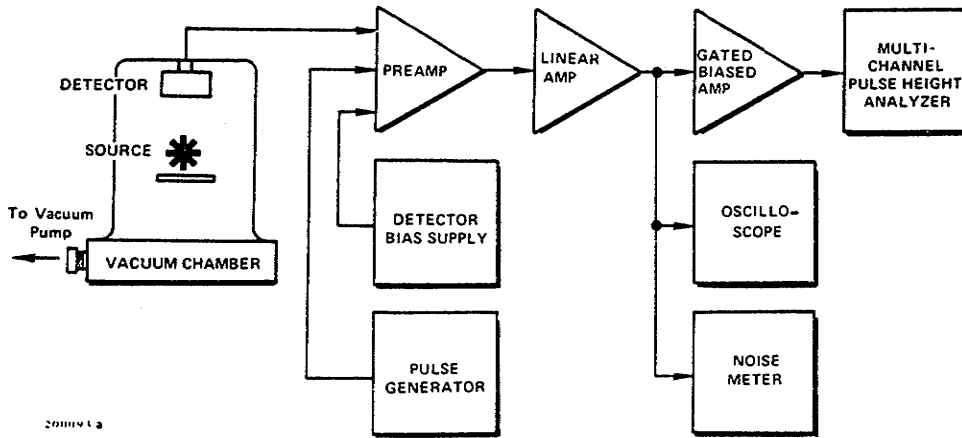

Fig. 4.17. System for High-Resolution Alpha-Particle Spectroscopy.

d. Operate at the highest allowable detector bias to keep the input capacity low.

SCINTILLATION-COUNTER GAMMA SPECTROSCOPY SYSTEMS The EG&G ORTEC 671 can be used in scintillation-counter spectroscopy systems as shown in Fig. 4.19. The amplifier shaping time constants should be selected in the region of 0.5 to 1 μ s for NaI or plastic scintillators. For scintillators having longer decay times, longer time constants should be selected.

X-RAY SPECTROSCOPY USING PROPORTIONAL COUNTERS Space charge effects in proportional counters, operated at high gas amplification, tend to degrade the resolution capabilities drastically at x-ray energies, even at relatively low counting rates. By using a high-gain low-noise amplifying system and lower gas amplification, these effects can be reduced and a considerable improvement in resolution can be obtained. The block diagram in Fig. 4.20 shows a system of this type. Analysis can be accomplished by simultaneous acquisition of all data on a multichannel analyzer or counting a region of interest in a single-channel analyzer window with a counter and timer or counting ratemeter.

4.12. OTHER EXPERIMENTS

Block diagrams illustrating how the 671 and other EG&G ORTEC modules can be used for experimental setups for various other applications are shown in Figs. 4.21 through 4.24.

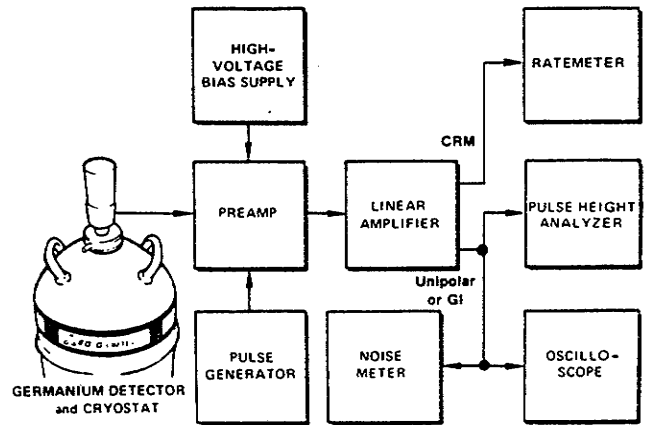

Fig. 4.18. System for High-Resolution Gamma Spectroscopy.

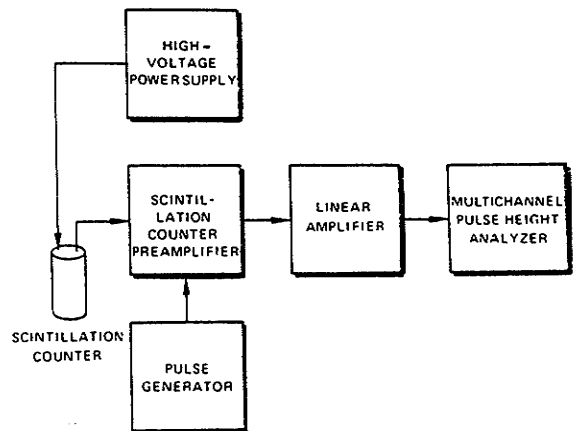

Fig. 4.19. Scintillation-Counter Gamma Spectroscopy System.

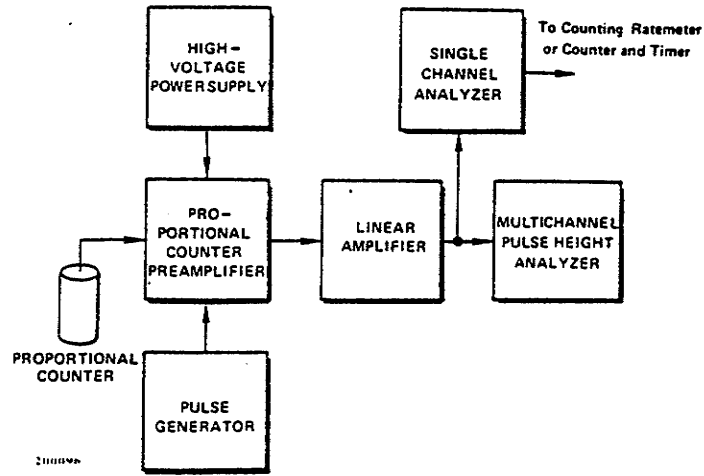

Fig. 4.20. High-Resolution X-Ray Energy Analysis System Using a Proportional Counter.

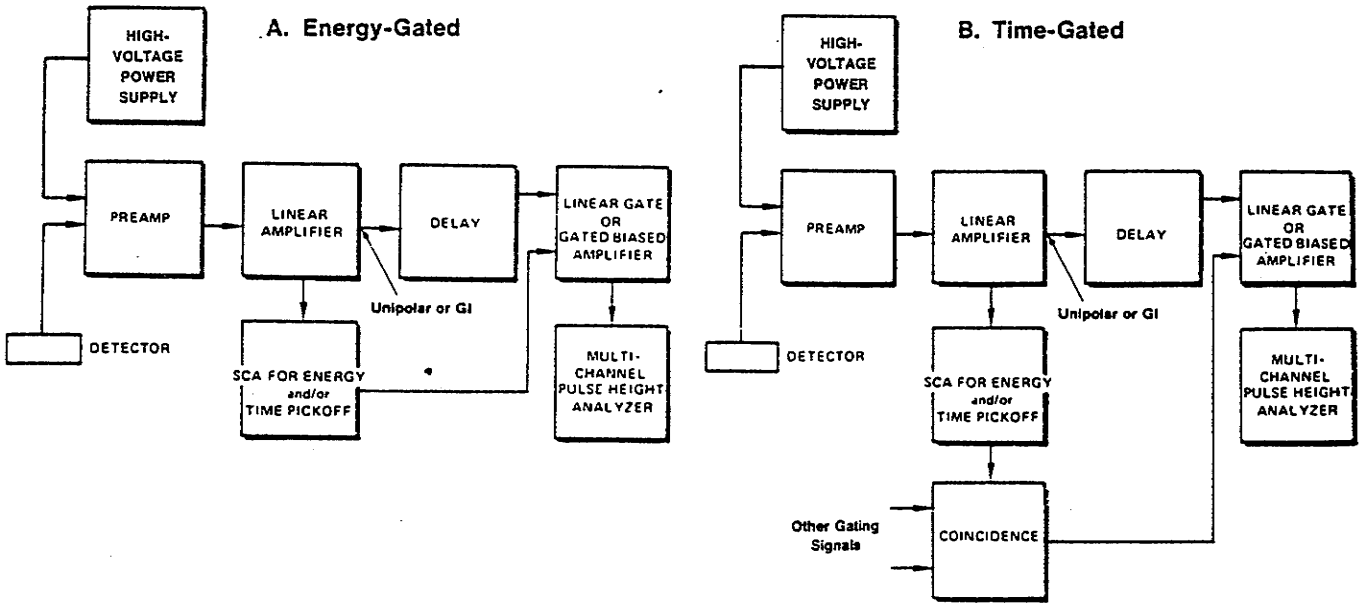

Fig. 4.21. General System Arrangement for Gating Control.

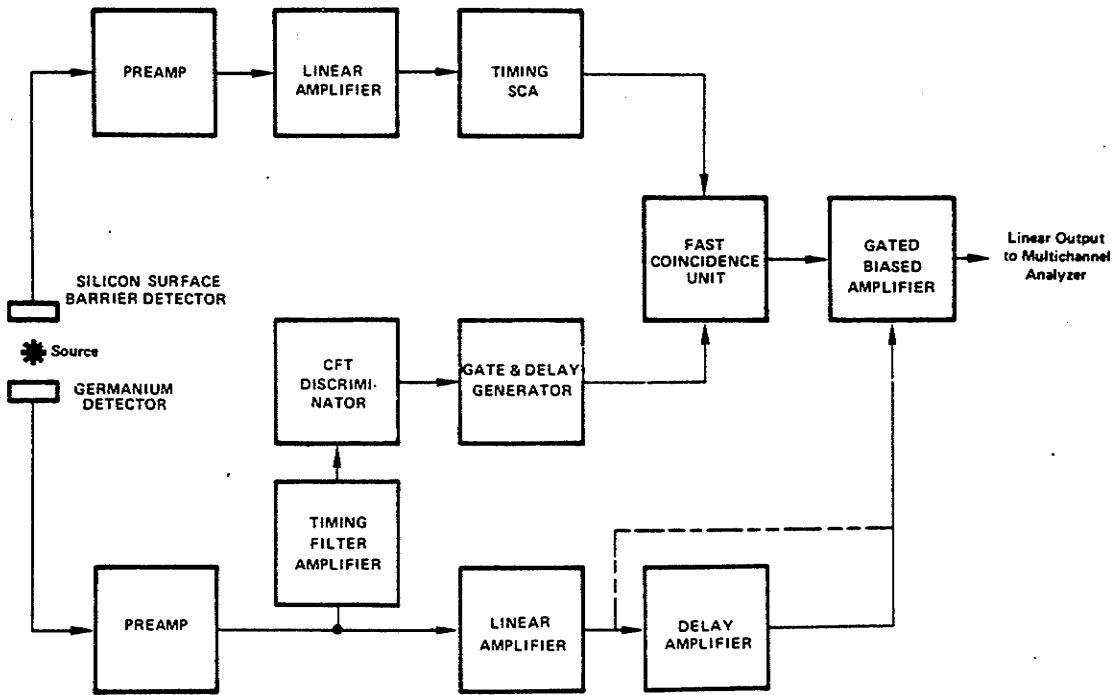

Fig. 4.22. Gamma-Ray Charged-Particle Coincidence Experiment.

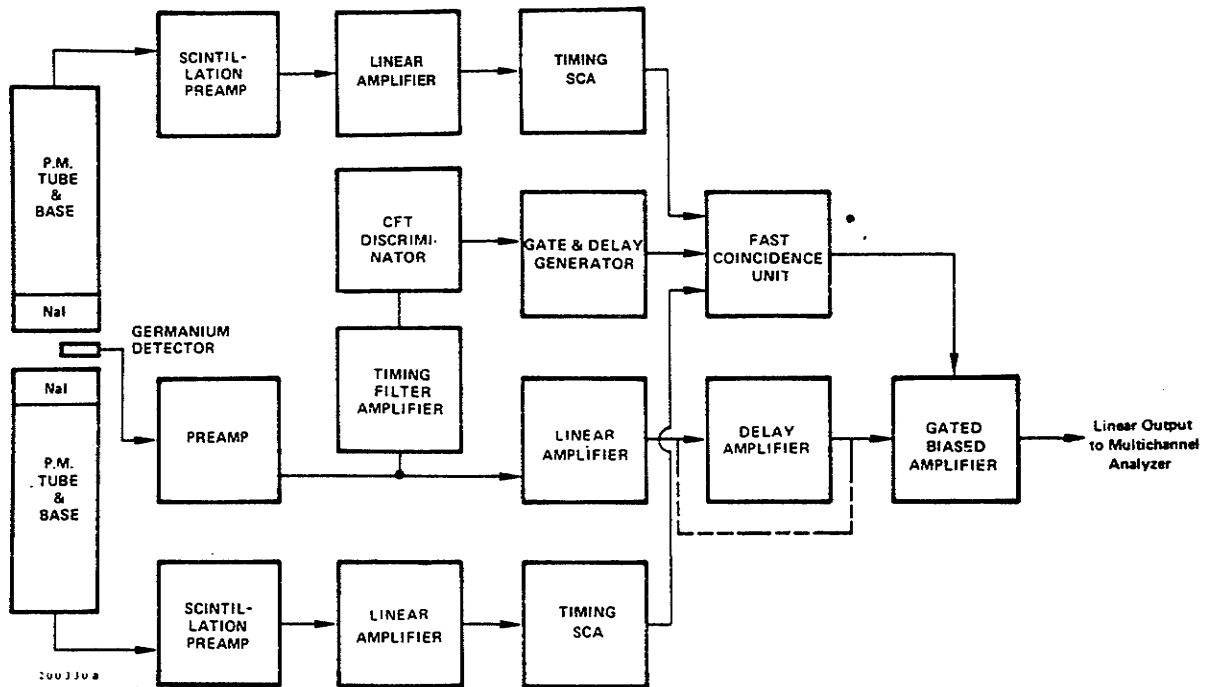

Fig. 4.23. Gamma-Ray Pair Spectroscopy.

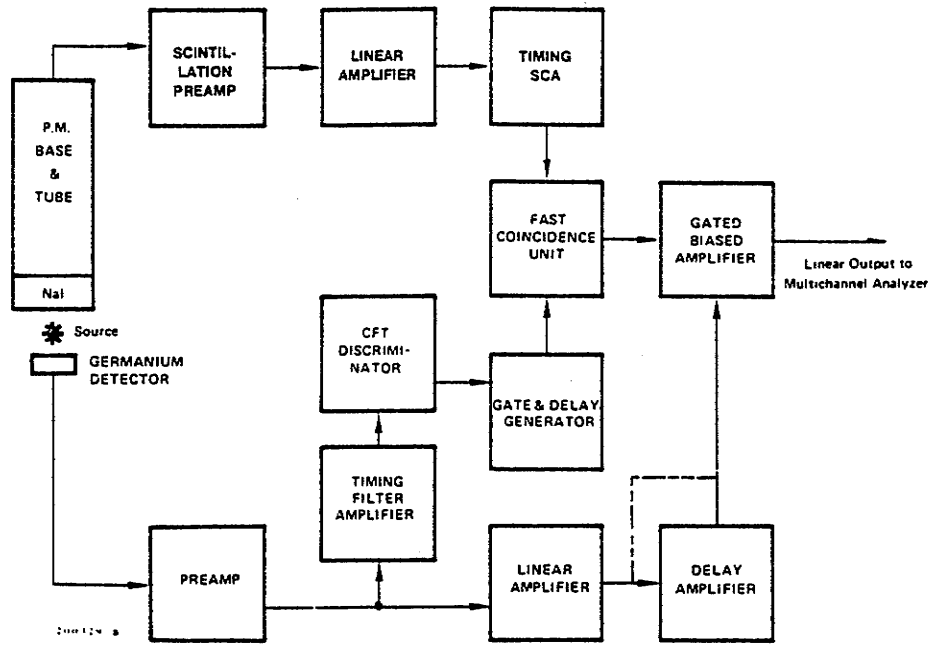

Fig. 4.24. Gamma-Gamma Coincidence Experiment.

5. CIRCUIT DESCRIPTION

5.1. INTRODUCTION

The schematic diagrams for the 671 Spectroscopy Amplifier and Pile-Up Rejector are included at the back of the manual. A block diagram of the amplifier section is also found in the back of the manual.

The 671 amplifier selects, amplifies, and shapes analog signal data from either a Pulsed Reset or a dc (resistor) Feedback preamplifier. The analog output pulses from the amplifier are sent to an analog-to-digital converter or other desired instrument. Input signal selection permits operating the amplifier in the Normal or Differential input mode with either positive or negative input pulses. The amplifier performs baseline restoration at varying count rates, pile-up inspection and rejection, automatic noise discrimination, pole-zero adjustment, and pulse shaping functions. When operating with Pulsed Reset Preamplifiers, the amplifier automatically determines the minimum reset recovery protection time required (no manual adjustment is needed).

A total of 12 different shaping times are provided from the combination of six front-panel shaping times with choice of either triangular or semi-Gaussian. The Gaussian shaping is an eight-pole filter consisting of two real poles and three complex pole pairs. Two complex zero pairs are added when the shaping is switched to the triangle mode.

5.2. INPUT POLARITY AND NORM/DIFF SWITCH

The Input Polarity and NORM/DIFF switches select either the Normal or Differential Input mode of operation and the input polarity (positive or negative). When the amplifier is in the Differential (DIFF) Input mode, the rear-panel input is used to cancel common mode pick-up introduced through the preamplifier ground. The rear-panel input is connected to the preamplifier ground through a resistance that is equal to the output impedance (93 or 100 Ω for most EG&G ORTEC preamplifiers) of the normal preamplifier output. This provides two noise signals to the 671 Amplifier, which uses the Differential Input Amplifier to cancel the common mode noise.

5.3. DIFFERENTIAL INPUT AMPLIFIER STAGE

The Differential Input Amplifier provides gain and buffering of the input signals from the Input Polarity and NORM/DIFF Switches. The analog input signal to the Differential Input Amplifier may be either a staircase of step pulses from a Pulsed Reset Preamplifier or a series of step pulses with exponential decay from a dc (resistor/continuous) Feedback

Preamplifier. When the amplifier is in the Differential Input mode, the differential reference input cancels common mode pickup introduced through the preamplifier ground.

The output pulse is positive with a gain of 1.8 for a Coarse Gain selection of 10 or more and a gain of 0.9 for Coarse Gain of 5. The output of this stage is provided to the Differentiator and the Pole-Zero adjustment circuit.

5.4. DIFFERENTIATOR AND FINE GAIN STAGE

The Differentiator and Fine Gain stage differentiates, provides a gain of 1.6 to 4.8, and inverts the analog signal from the Input Amplifier. The output of this stage is provided to the Coarse Gain stages. The differentiator network contains six sets of capacitors, which with R11 and R12 set the time constant for the first real pole.

The front-panel PZ adjust pot R28 connects through hybrid resistor network A3 and R24 to the input of the Differentiator stages. Pole-zero cancellation is used to compensate for pulse undershoot when the trailing edge of a differentiated pulse is returning to the baseline. The trailing edge of the pulse should return to the baseline as quickly as possible without undershoot. Proper adjustment prevents spectral resolution degradation and peak shift at high counting rates. Pole-zero cancellation adjustment procedures are contained in Section 4.

5.5. COARSE GAIN STAGES

The Coarse Gain stages provide coarse gain settings from 10 to 1000. The coarse gain of 5 results from reducing the gain of the Differential Input Amplifier as discussed in Section 5.3. The amplifier coarse gain is accomplished by two nearly identical inverting amplifier stages (Gain stage A and Gain stage B). The gain of each stage is switched to 1, 2, 5, or 10 by means of hybrid FET Gain Networks, A4 and A5, to provide the gain selected by the front-panel Coarse Gain switch. Analog signals do not go through the mechanical contacts of the Coarse Gain switch.

The output of Coarse Gain stage B is sent to the Integrator stages, the Fast Amplifier, and the Gain dc stabilizer.

5.6. GAIN DC STABILIZER

The Gain dc Stabilizer circuitry is used to maintain the dc level at the output of Coarse Gain stage B near zero

volts over the range of gains and temperatures. The Gain dc Stabilizer circuitry monitors the output of Coarse Gain B, integrates the error voltage, and produces an offset current through R18 to the Differentiator stage to slowly restore the output to zero volts. The time constant is long enough to be neglected in the overall transfer function of the amplifier.

5.7. INTEGRATOR STAGES

Three Sallen-Key type Integrator stages, F1, F2, and F3, provide three complex pole pairs to the pulse shaping prior to sending the Unipolar and Bipolar Output stages. Each Integrator stage contains two hybrid resistor networks with six resistors in each network. Six values of resistances are available in each network for selection in setting the shaping time constant desired for operation. The output pulses from the third Integrator stage are nearly Gaussian.

5.8. UNIPOLAR OUTPUT STAGE

The Unipolar Output stage provides the final amplification, shaping, baseline restoration, and drive for the front- and rear-panel output connectors. The gain provided is negative 2.9, and the second real pole is implemented with a time constant of one-third the Input Differentiator. Selection of Triangle Mode shaping sums fractions of the first and second Integrator stages with the third Integrator through relay RLY3 to provide a triangular shaped Unipolar Pulse.

5.9. BIPOLAR OUTPUT STAGE

The output of Integrator F3 is also provided to the Bipolar Output stage through a second differentiator.

5.10. GATED BASELINE RESTORER

The Gated Baseline Restorer (BLR) circuit centers the Unipolar Output noise band between pulses around ground. The BLR circuit consists of the gain of 7 amplifier, U16, gated transconductance amplifier, U14, with C77 and buffer amplifier, U15. The capacitor, C77, averages the noise and dc-level at the Unipolar Output at a rate set by the front-panel BLR Rate switch. The charge on the capacitor is used to control the offset to the positive input of the Unipolar Output stage. The transconductance amplifier is gated off when a signal is present to prevent the baseline from shifting as the count-rate varies.

The BLR Rate can be set in PZ, Auto, and High. The restoration rate is set by controlling the current through the transconductance amplifier. The current and thus the BLR Rate is very slow in the PZ position so

that PZ observation is not disturbed. The restoration rate in the Auto position is automatically increased as the count-rate increases, taking into account the shaping time, as the dead time increases. The High position is provided for special cases, such as when a low-frequency or medium-frequency disturbance is present and is independent of the counting rate.

5.11. SLOW DISCRIMINATORS

The Slow Discriminators monitor the Unipolar Output signal to determine when selected thresholds are reached. The Slow Discriminator circuitry contains: an Automatic Noise Level Sensor, A16, a Slow Positive Discriminator, U28A, and a Slow Negative Discriminator, U28B. The Automatic Noise Level Sensor sets the threshold level for the Positive Discriminator just above noise. The threshold for the Negative Discriminator is three times the noise level set for the Positive Discriminator. Only pulses that exceed the Automatic Noise Level Sensor threshold will produce outputs from the Slow Discriminators. The outputs from the discriminators are used to gate off the Gated Baseline Restorer when a pulse is detected.

5.12. FAST DIFFERENTIATOR AND AMPLIFIER

The Fast Differentiator and Amplifier process the output of Coarse Gain B to provide a dc-restored, pole-zeroed, 90-ns differentiated signal to the Fast Discriminator. A gated transconductance amplifier, U31, accomplishes the Fast Gated BLR function.

5.13. FAST DISCRIMINATOR

The Fast Discriminator monitors the output of the Fast Amplifier to determine when the Fast Amp signal threshold is reached. The Fast Discriminator circuitry contains a Fast Auto Noise Sensor to set the threshold of the Fast Discriminator just above the noise in the Fast Channel. An output from the Fast Discriminator is sent to the Pile-up Inspector which uses the signal to check for pulse pile-up. The output also triggers a 250-ns one-shot to provide the Count Rate Meter (CRM) pulse to the rear panel.

5.14. PILE-UP INSPECTOR

The Pile-up Inspector circuit provides a Reject signal to prevent processing and analyzing of distorted pulses caused by pulse pile-up. Pulse pile-up is caused by two or more closely spaced (overlapping) pulses that sum together to produce a higher amplitude (distorted) pulse. The Pile-up Inspector monitors the output of the Fast Discriminator. Each

time the Fast Amplifier pulse exceeds the noise threshold set by Auto Noise Level Sensor output, the Fast Discriminator produces a logic pulse. The first pulse detected by the Pile-up Inspector sets an inspect interval; if a second pulse occurs within the inspect interval, the inspect interval is retriggered and a Reject is generated.

Figure 5.1 illustrates the relative timing of the signals in the 671. The solid-line waveforms show a normal response to a single linear input signal from the preamplifier without any pulse pile-up condition. The broken-line waveforms show the modifications that occur when there is a pile-up condition.

The PUR signal is sent to the PUR (Pile-Up Reject) input of the MCA, such as an EG&G ORTEC ADCAM® with 8K ADC. The 8K ADC uses the PUR signal to inhibit analog-to-digital conversion of the distorted pulse and to turn off the livetime clock. If the PUR occurs before peak detect occurs in the ADC, both the original pulse and pulse causing the pile-up are rejected. If the PUR occurs after peak detect, the first pulse amplitude was not distorted and only the second pulse is rejected. Not all pile-up pulses are rejected. Pile-ups that occur within the duration of the Fast Amplifier pulse cannot be resolved and will be processed even though they are distorted pulses. Each time an inspect interval is generated, a Busy signal is generated that can be connected to the ADC Busy In connector to generate a livetime correction signal for the ADC.

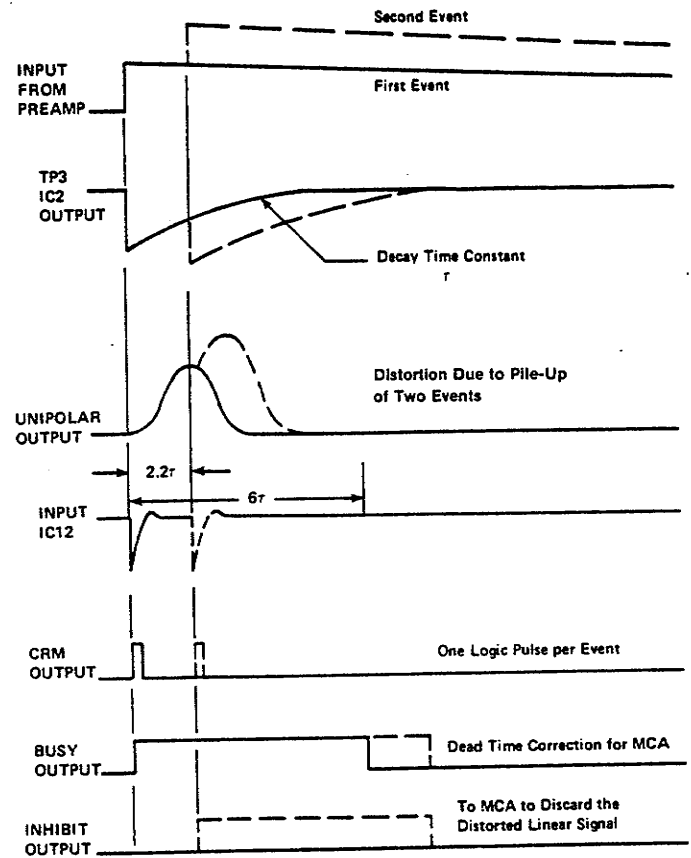

Fig. 5.1. Timing Relations in the 671 Amplifier and Pile-Up Rejector.

6. MAINTENANCE

6.1. TEST EQUIPMENT REQUIRED

The following test equipment should be utilized to adequately test the specifications of the 671 Spectroscopy Amplifier.

1. EG&G ORTEC 419 Precision Pulse Generator or 448 Research Pulser.
2. Tektronix 465, 475, or 485 Series Oscilloscope or equivalent with bandwidth greater than 100 MHz.
3. Hewlett-Packard 3400A RMS Voltmeter.

6.2. PULSER TEST*

Coarse Gain	1K
Fine Gain	1.5
Input Polarity	Positive
Shaping Time Constant	2 μ s
BLR Rate	PZ
UNI Shaping	Gaussian

a. Connect a positive pulser output to the 671 input and adjust the pulser to obtain +10 V at the 671 Unipolar output. This should require an input pulse of 6.6 mV using a 100- Ω terminator at the input. Switch Unipolar Mode to Triangle. This should also be 10 V.

b. Measure the positive lobe of Bipolar output. This should also be +10 V.

c. Change the Input polarity switch to Neg and then back to Pos while monitoring the outputs for a polarity inversion. The negative output should clamp at -1 V.

d. Decrease the Coarse Gain switch stepwise from 1K to 5 and ensure that the output amplitude changes by the appropriate amount for each step. Return the Coarse Gain switch to 1K.

e. Decrease the Fine Gain control from 1.5 to 0.5 and check to see that the output amplitude decreases by a factor of 3. Return the Fine Gain control to maximum at 1.5.

f. With the Shaping Time switch set for 1 μ s, measure the time to the peak on the unipolar output pulse; this should be 2.2 μ s for 2.2 τ .

g. Change the Shaping Time switch to 0.25 through 6 μ s. At each setting, check to see that the time to the unipolar peak is 2.2 τ . Return the switch to 1 μ s.

OVERLOAD TESTS Start with maximum gain, $\tau=2$ μ s, and a +10 V output amplitude. Increase the pulser output amplitude by X1000 and observe that

the unipolar output returns to within 200 mV of the baseline within 27 μ s after the application of a single pulse from the pulser. It will probably be necessary to vary the PZ Adj control on the front panel in order to cancel the pulser pole and minimize the time required for return to the baseline.

LINEARITY The integral nonlinearity of the 671 can be measured by the technique shown in Fig. 6.1. In effect, the negative pulser output is subtracted from the positive amplifier output to cause a null point that can be measured with excellent sensitivity. The pulser output must be varied between 0 and 10 V, which usually requires an external control source for the pulser. The amplifier gain and the pulser attenuator must be adjusted to measure 0 V at the null point when the pulser output is 10 V. The variation in the null point as the pulser is reduced gradually from 10 V to 0 V is a measure of the nonlinearity. Since the subtraction network also acts as a voltage divider, this variation must be less than

$$(10 \text{ V full scale}) \times (\pm 0.025\% \text{ maximum nonlinearity}) \\ \times (1/2 \text{ for divider network}) = \pm 1.25 \text{ mV} \\ \text{for the maximum null-point variation.}$$

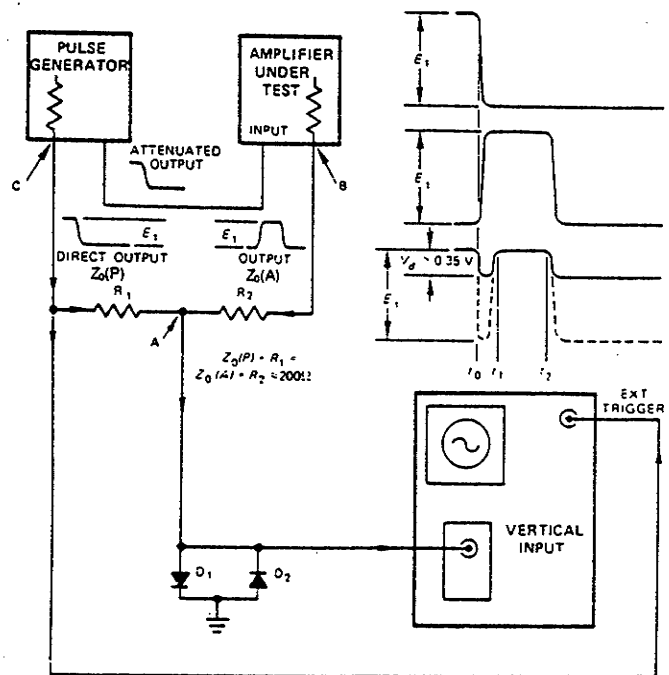

Fig. 6.1. Circuit Used to Measure Nonlinearity.

*See IEEE Standards, No. 301-1976.

OUTPUT LOADING Use the test setup of Fig. 6.1. Adjust the amplifier output to 10 V and observe the null point when the front-panel output is terminated in 100 Ω . The change should be <5 mV.

NOISE Measure the noise at the amplifier Unipolar output with maximum amplifier gain and 2- μ s shaping time. Using a true rms voltmeter, the noise should be less than $5 \mu V \times 1500$ (gain), or 7.5 mV.

For an average responding voltmeter, the noise reading would have to be multiplied by 1.13 to calculate the rms noise. The input must be terminated in 100 Ω during the noise measurements.

6.3. SUGGESTIONS FOR TROUBLESHOOTING

In situations where the 671 is suspected of a malfunction, it is essential to verify such malfunction in terms of simple pulse generator impulses at the input. The 671 must be disconnected from its position in any system and routine diagnostic analysis performed with a test pulse generator and an oscilloscope. It is imperative that testing not be performed with a source and detector until the amplifier performs satisfactorily with the test pulse generator.

The testing instructions in Section 6.2 and the circuit descriptions in Section 5 should provide assistance in locating the region of trouble and repairing the malfunction. The two side plates can be completely removed from the module to enable oscilloscope and voltmeter observations.

6.4. FACTORY REPAIR

This instrument can be returned to the EG&G ORTEC factory for service and repair at a nominal cost. Our standard procedure for repair ensures the same quality control and checkout that are used for a new instrument. Always call Customer Services at EG&G ORTEC, (615) 482-4411, before sending in an instrument for repair to obtain shipping instructions and so that the required Return Authorization Number can be assigned to the unit. This number

should be marked on the address label and on the package to ensure prompt attention when the unit reaches the factory.

6.5. TABULATED TEST POINT VOLTAGES

The voltages given in Table 6.1 are intended to indicate typical dc levels that can be measured on the PWB. In some cases the circuit will perform satisfactorily even though, due to component tolerances, there may be some voltage measurements that differ slightly from the listed values. Therefore, the tabulated values should not be interpreted as absolute voltages, but are intended to serve as an aid in troubleshooting.

Table 6.1. Typical dc Voltages*

Location	Voltage
TP1	± 25 mV
TP2	± 25 mV
TP3	± 25 mV
TP4	± 10 mV
TP5	± 10 mV
TP6	± 25 mV
TP7	± 40 mV
TP8	± 50 mV
TP9	-12.5 V
TP10	-11.4 V
TP11	+0.05 to +0.2 V
TP12	-0.5 V
TP13	HC Logic 0
TP14	HC Logic 1
TP15	± 25 mV
TP16	-0.4 V
TP17	+0.05 to +0.2 V
TP18	-11.3 V
UNI Out	± 5 mV
BI Out	± 10 mV

*All voltages measured with no input signal, with the input terminated in 100 Ω , and all controls set fully clockwise at maximum.

**BIN/MODULE CONNECTOR PIN ASSIGNMENTS .
FOR STANDARD NUCLEAR INSTRUMENT
MODULES PER DOE/ER-0457T**

Pin	Function	Pin	Function
1	+3 volts	23	Reserved
2	-3 volts	24	Reserved
3	Spare Bus	25	Reserved
4	Reserved Bus	26	Spare
5	Coaxial	27	Spare
6	Coaxial	*28	+24 volts
7	Coaxial	*29	-24 volts
8	200 volts dc	30	Spare Bus
9	Spare	31	Spare
*10	+6 volts	32	Spare
*11	-6 volts	*33	117 volts ac (Hot)
12	Reserved Bus	*34	Power Return Ground
13	Spare	35	Reset (Scaler)
14	Spare	36	Gate
15	Reserved	37	Reset (Auxiliary)
*16	+12 volts	38	Coaxial
*17	-12 volts	39	Coaxial
18	Spare Bus	40	Coaxial
19	Reserved Bus	*41	117 volts ac (Neut.)
20	Spare	*42	High Quality Ground
21	Spare	G	Ground Guide Pin
22	Reserved		

Pins marked (*) are installed and wired in EG&G ORTEC's 4001A and 4001C Modular System Bins.

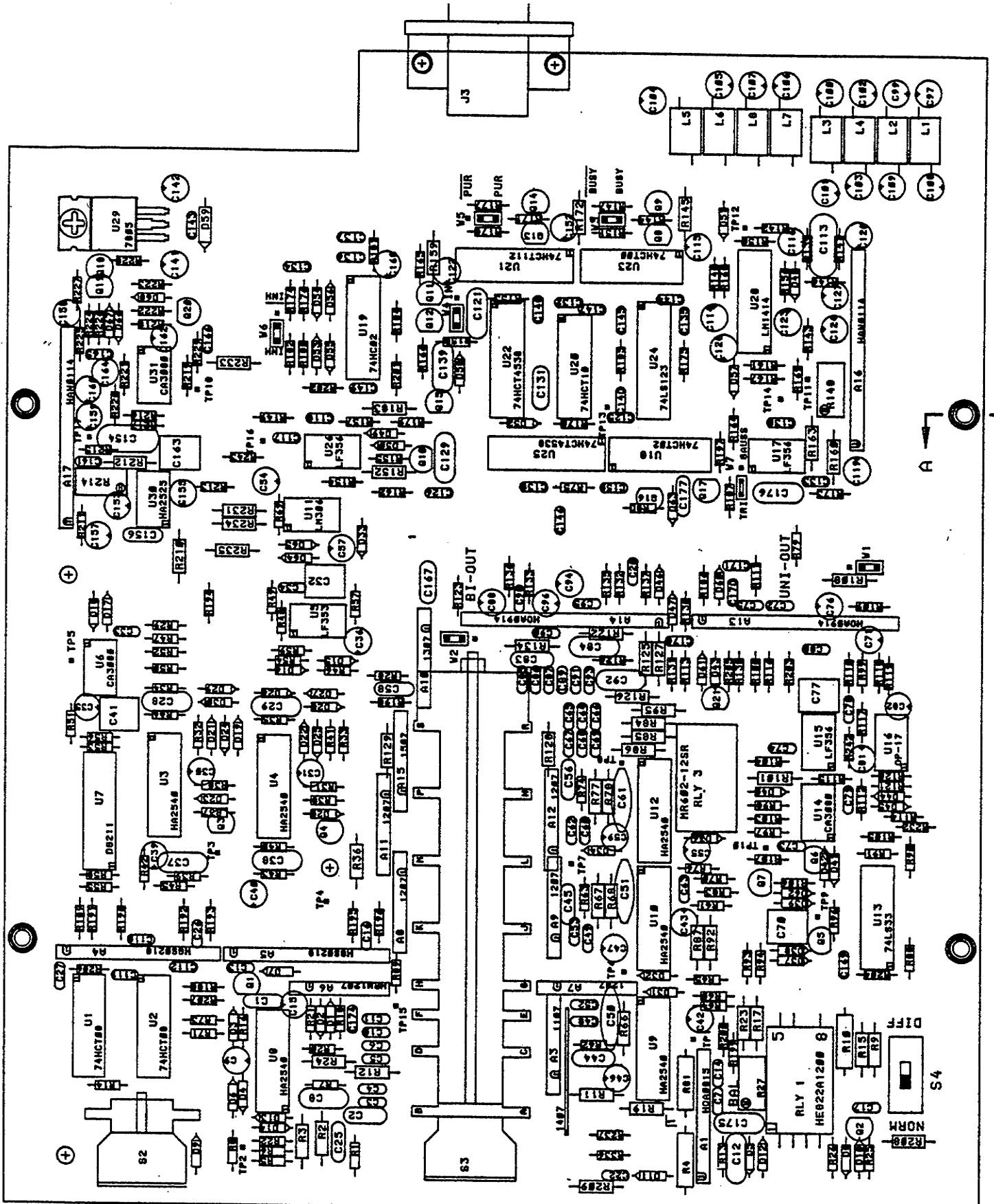

671 ASSY 746240C

C ORT-792 12-7-79 B ORT-535 8/18/79 REV. NO. 1/1		100 MIDLAND ROAD, OAK RIDGE, TENNESSEE 37830 MODEL 671 PWB ASSY, AMPLIFIER	
T BECKER 11/10/79		730030 746240	
2/11		D	

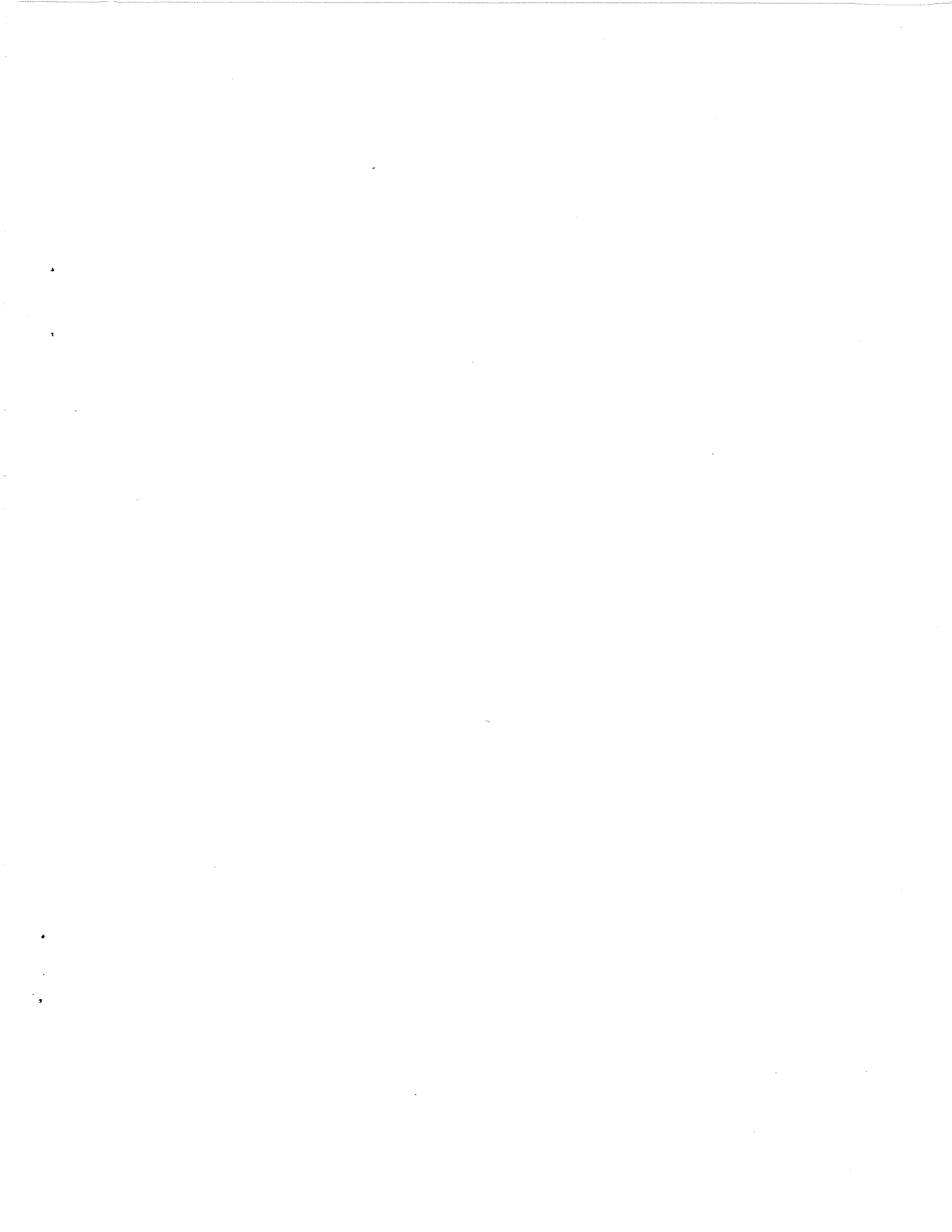



For more information on EG&G ORTEC products and their applications contact your local EG&G ORTEC representative or:

United States

100 Midland Road, Oak Ridge, TN 37831-0895 U.S.A.
Telephone: (423) 482-4411 or (800) 251-9750
Email: INFO_ORTEC@egginc.com Fax: (423) 483-0396

Austria

(01) 91422510

Canada

(800) 268-2735

France

04.76.90.70.45

Germany

(07081) 1770

Italy

(02) 27003636

Japan

(047) 3927888

People's Republic of China

(010) 65544525

Russia

(095) 9379504

United Kingdom

(01189) 773003